

**GRATING  
PACIFIC**

PRODUCTS & SERVICES GUIDE

The central graphic features a dark blue background with a subtle pattern of grating. On the left, there are three small icons: a square grid, a diamond pattern, and a circular pattern. The text "GRATING PACIFIC" is written in large, bold, white capital letters. Below it, "PRODUCTS & SERVICES GUIDE" is written in a smaller, white, sans-serif font.

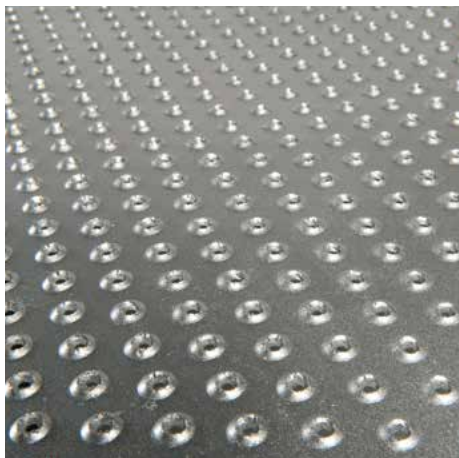

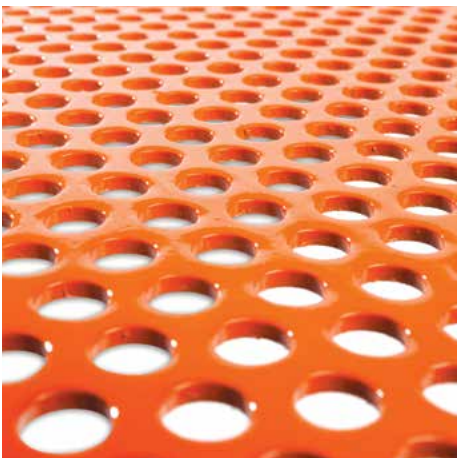
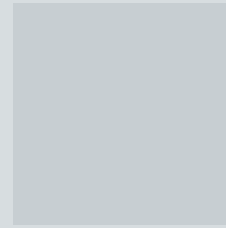

Since its founding in 1971, **Grating Pacific** has grown into the Western United States' premier fabricator of metal and fiberglass industrial flooring, and architectural metal products. Our five facilities are strategically located in Arizona, California, Oregon, and Washington, allowing us to provide unparalleled service to our customers.

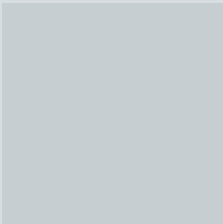

At Grating Pacific, we pride ourselves on offering the highest quality products delivered with industry leading customer service. Our extensive list of products and services provides each customer with an experience specifically tailored to their project needs. Technical sales team members provide comprehensive product information, while our engineering staff stands ready to generate custom CAD designs and engineering certification. Following your approval, our production team will cut, shear, weld, form, frame, or do whatever it takes to exceed your expectations.

Grating Pacific's range of premium products are the basis of our best-in-class services. From stylish architectural pieces to demanding, functional components, Grating Pacific offers a wide range of customizable products designed to meet your project needs.

We provide customers with quality products that provide continuing value, safety, and durability. Please explore the following pages and consider which products suit your application. We are ready to assist in your selection and deliver excellence to your project on the most demanding schedule.

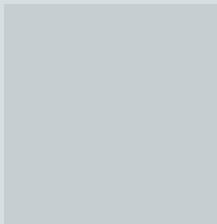

# CONTENTS

<b>4</b>	<b>METAL BAR GRATING</b>	
	Introduction	6
	Specification	7
	Steel Bar Grating	9
	Aluminum Bar Grating	10
	Stainless Steel Bar Grating	11
	Bar Grating Stair Treads	12
	Aluminum Plank Grating	13
	Riveted Bar Grating	13
	Heavy Duty Bar Grating	14
	Embed Frames	16
	Trench & Inlet Systems	17
	Installation & Fasteners	20
	Fabrication	21
<hr/>		
<b>22</b>	<b>CODA ARCHITECTURAL</b>	
	Opus Architectural	24
	Aria Architectural	25
	Architectural Bar Grating	26
	Aluminum Louver Grates	27
<hr/>		
<b>28</b>	<b>SAFETY GRATING</b>	
	Grip Strut Safety Grating	30
	Heavy Duty Grip Strut	32
	Perf-O Grip Safety Grating	34
	Grate-Lock Safety Grating	36
	Traction Tread Safety Grating	38
	Safety Grating Ladder Rungs	39
	Floor Resurfacing Products	40
	Walkway Channels	41
	Safety Grating Stair Treads	42
<hr/>		
<b>43</b>	<b>FIBERGLASS GRATING</b>	
	Introduction	44
	Molded Fiberglass Grating	46
	Pultruded Fiberglass Grating	48
	High Load Capacity Grating	50
	Stair Treads & Stair Covers	51
	Molded Patterns & Screens	52
	Fiberplate FRP Floor Plate	52
	Fiberglass Embed Angle	53
	Dynaform FRP Products	53
<hr/>		
<b>54</b>	<b>WIRE MESH</b>	
	Specifications	56
	Welded Wire Mesh	58
	Woven Wire Mesh	59
	Wire Mesh Rolls	59
	Duetto Landscape Screens	60
<hr/>		
<b>61</b>	<b>PERFORATED METAL</b>	
	Introduction	63
	Sizes & Options	64
	Pattern Illustrations	66
<hr/>		
<b>69</b>	<b>EXPANDED METAL</b>	
	Introduction	71
	Standard Expanded Metal	72
	Flattened Expanded Metal	73
	Expanded Metal Grating	74
<hr/>		
<b>75</b>	<b>ACO TRENCH DRAIN SYSTEMS</b>	
	KlassikDrain	77
	PowerDrain	78
	FlowDrain & BrickSlot	78
	Grates & Catch Basins	79
	HighwayDrain & TraffikDrain	79
<hr/>		
<b>80</b>	<b>STAIR NOSINGS</b>	
	SuperTread Nosings	81
	Cast Abrasive Nosings	83
<hr/>		
<b>84</b>	<b>ONGRIP &amp; ALGRIP SLIP-RESISTANT FLOORING</b>	
	OnGrip Surface	85
	Algrip Surface	85
	Ladder Rungs	85
<hr/>		
<b>86</b>	<b>DOCK SOLUTIONS</b>	
	Thru-Flow	87
	SunWalk	87
	Ecograte	87



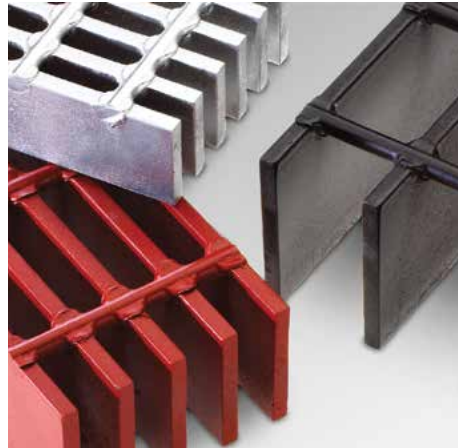

# METAL BAR GRATING

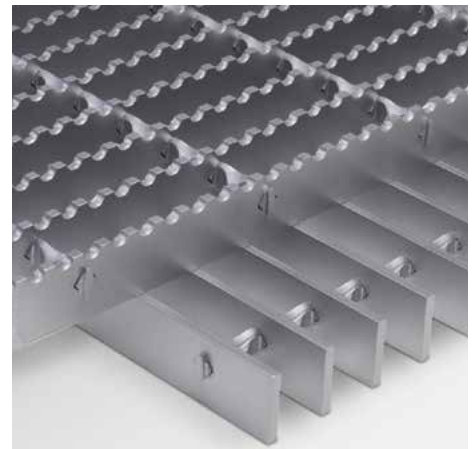



## METAL BAR GRATING

Metal bar grating is the workhorse of the industrial flooring market. Features that make bar grating the preferred choice for open metal flooring include:

- Manufactured in steel, aluminum, or stainless steel
- High strength-to-weight ratio
- High percentage of open area
- Easily fabricated to any configuration
- Essentially maintenance-free



## Metal Bar Grating Products

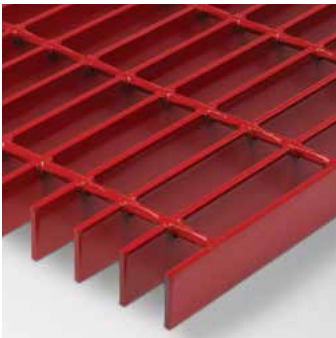

**Steel**



**Aluminum**



**Stainless Steel**



**Stair Treads**

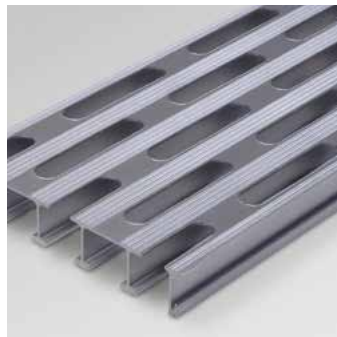

**Aluminum Plank Grating**



**Riveted**

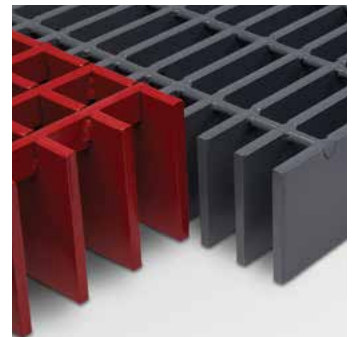

**Heavy Duty**

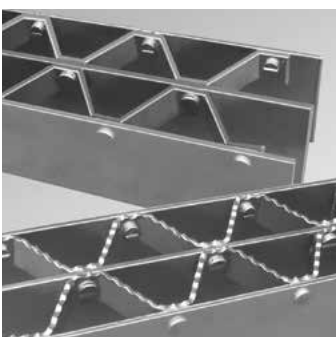

**Bridge Decking**

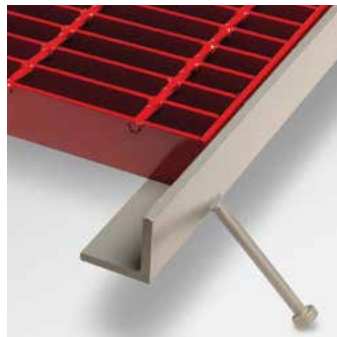

**Embed Frames**



**Trench & Inlet Systems**



**Architectural Products**

## INTRODUCTION

Metal bar grating is manufactured by assembling a series of equally spaced metal bars to connecting cross bars. Common materials available include mild carbon steel, 6000 series aluminum, and 300 series stainless steel. Grating Pacific also has the capacity to produce gratings constructed with other specialty metal alloys.

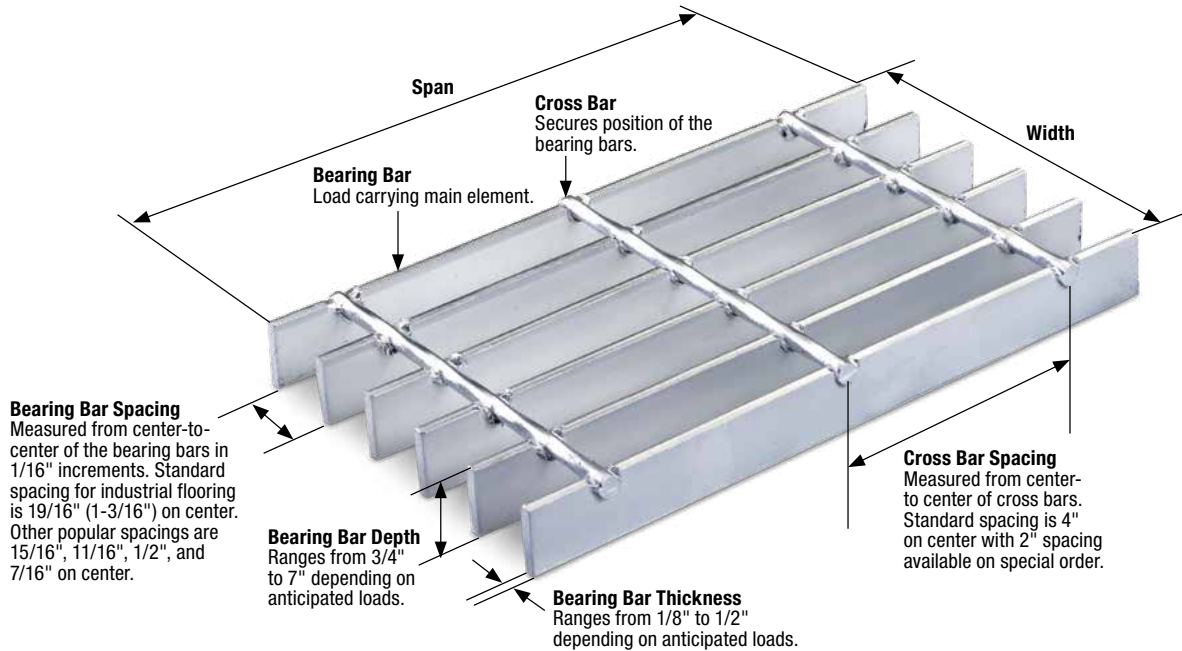

## MANUFACTURING METHODS

### Welded Grating

Economical design ideal for most industrial applications. Manufactured by welding the bearing bar and cross bar intersection, typically with automated forge welding equipment. Available in carbon and stainless steel.

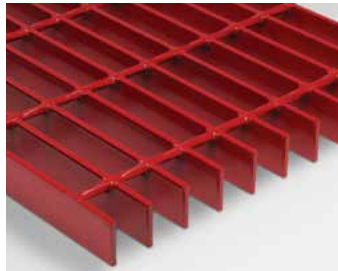

### Swage Locked Grating

Popular for the manufacture of aluminum, stainless steel, and close mesh gratings. Cross bars are inserted into pre-punched holes in the bearing bars and hydraulically deformed to lock the bars in place.



### Dovetail Pressure Locked Grating

Assembled by inserting pre-punched bearing and cross bars into an "eggcrate" configuration and deforming the cross bars under intense hydraulic pressure. Available in all materials and ideal for architectural and ornamental applications.



### Riveted Grating

Exceptionally durable grating manufactured by riveting bearing bars and bent connecting bars at their contact points. Excellent for applications involving impact loads and repetitive traffic patterns.





## SPECIFICATION CRITERIA

When specifying metal bar grating, it is important to consider:

- Service load required and acceptable deflection
- Unsupported clear span
- Walking surface
- Banding and trim
- Finish

### Service Loads

Please visit our website for load tables and deflection criteria for most common applications. Pedestrian loads are commonly analyzed with uniform and concentrated loads. For pedestrian comfort, deflection is typically limited to 1/4". Heavy duty and vehicular load tables are presented for specific load conditions with deflection limited to the lesser of 1/8" or L/400. If your application is not addressed by the load tables found on our website, please contact us for assistance in selecting the most appropriate product for your application.

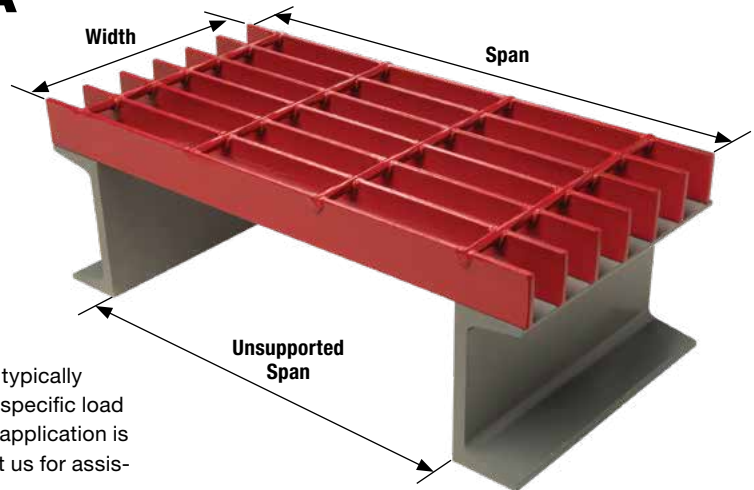

## Surface Options

### Plain Surface

Standard surface with excellent "self-cleaning" characteristics. Suitable for most applications.

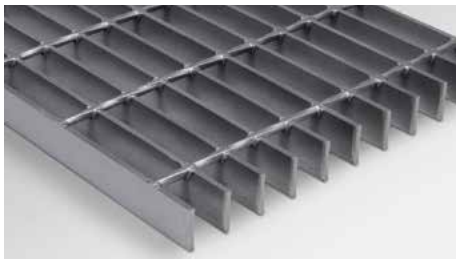

### Serrated Surface

Preferred for applications where moisture or fluids cause the walking surface to become wet and slippery.

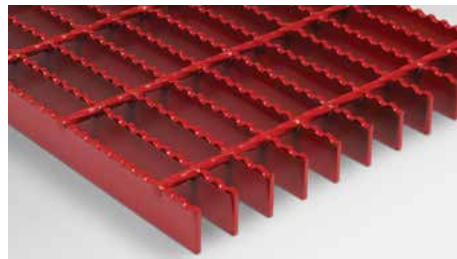

### OnGrip™ Surface

Durable slip-resistant walking surface provides enhanced traction for applications in the public way.



### Banding

Banding is an option to protect the open ends of the grating panel, and may be specified on any grating product. Many applications benefit significantly from banding which provides additional transverse stiffness and a finished architectural appearance.

Trench banding is an additional option where the band bar is elevated above the bottom of the bearing bars and is ideal for drainage applications.



Standard Trim Banding

### Finishes

**STEEL** products are commonly provided with one of three finishes: bare steel (no finish); painted with one coat of manufacturer's red or black paint; or hot dip galvanized in accordance with ASTM A123.

**ALUMINUM** products are offered mill finish, with optional chemical cleaning or anodizing also available.

**STAINLESS STEEL** products typically require secondary cleaning due to discoloration that occurs during welding and fabrication. Commercial cleaning, passivation, or abrasive blasting can provide a uniform matte surface, while electro-polishing leaves a bright stainless finish.

**OTHER** - All products can be provided with specialty finishes including enamel or epoxy paints, powder coatings, or fluoropolymer coatings.

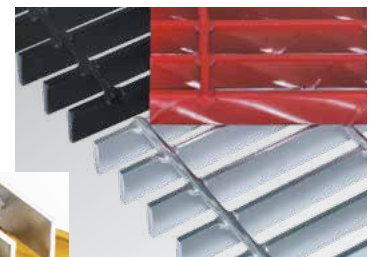

Painted Steel



Mill Finished & Anodized Aluminum

# METAL BAR GRATING

**METAL BAR GRATING TABLE OF SPACING**

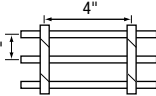
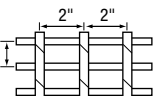
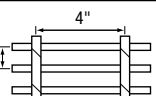
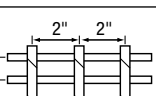
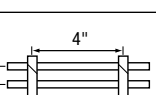
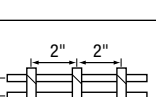
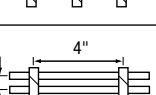
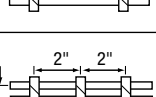
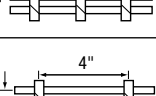
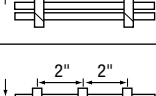
SPACING	OPEN AREA*	DESCRIPTION	PART NUMBER STEEL BAR GRATING	PART NUMBER ALUMINUM BAR GRATING	PART NUMBER STAINLESS STEEL BAR GRATING
 <p>1-3/16"</p>	78%	Bearing bars spaced at 1-3/16" on center and cross bars at 4" on center. The workhorse of industrial flooring, popular for platforms, catwalks, mezzanines, and stairways.	19-W-4	19-SG-4	19-WS-4
			19-SL-4	19-SGI-4	19-SLS-4
			19-DT-4	19-SGF-4	19-DTS-4
			—	19-ADT-4	—
 <p>1-3/16"</p>	73%	Bearing bars spaced at 1-3/16" on center and cross bars at 2" on center. Excellent for short spans and applications where small wheeled carts continuously cross the grating surface.	19-W-2	19-SG-2	19-WS-2
			19-SL-2	19-SGI-2	19-SLS-2
			19-DT-2	19-SGF-2	19-DTS-2
			—	19-ADT-2	—
 <p>15/16"</p>	75%	Bearing bars spaced at 15/16" on center and cross bars at 4" on center. The closer spaced bearing bars increase load capacity by more than 26% when compared to similar gratings produced with bearing bars at 1-3/16" on center.	15-W-4	15-SG-4	15-WS-4
			15-SL-4	15-SGI-4	15-SLS-4
			15-DT-4	15-SGF-4	15-DTS-4
			—	15-ADT-4	—
 <p>15/16"</p>	69%	Bearing bars spaced at 15/16" on center and cross bars at 2" on center. The closer spaced bearing bars and cross bars provide additional flooring surface to support pedestrian and wheeled traffic.	15-W-2	15-SG-2	15-WS-2
			15-SL-2	15-SGI-2	15-SLS-2
			15-DT-2	15-SGF-2	15-DTS-2
			—	15-ADT-2	—
 <p>11/16"</p>	68%	Bearing bars spaced at 11/16" on center and cross bars at either 4" or 2" on center. Types 11-4 and 11-2 with 3/16" thick bearing bars comply with the spacing requirements of the Americans with Disabilities Act. For ADA applications, specify that the bearing bars span perpendicular to the normal flow of traffic.	11-W-4	11-SG-4	11-WS-4
			11-SL-4	11-SGI-4	11-SLS-4
			11-DT-4	11-SGF-4	11-DTS-4
			—	11-ADT-4	—
 <p>11/16"</p>	63%		11-W-2	11-SG-2	11-WS-2
			11-SL-2	11-SGI-2	11-SLS-2
			11-DT-2	11-SGF-2	11-DTS-2
			—	11-ADT-2	—
 <p>1/2"</p>	58%	Bearing bars spaced at 1/2" on center and cross bars at 4" or 2" on center. Types 8-4 and 8-2 comply with ADA spacing requirements. These products are popular for material handling platforms and mezzanines subject to continuous cart and dolly traffic.	8-W-4	8-SG-4	8-WS-4
			8-SL-4	8-SGI-4	8-SLS-4
			8-DT-4	8-SGF-4	8-DTS-4
			—	8-ADT-4	—
 <p>1/2"</p>	54%		8-W-2	8-SG-2	8-WS-2
			8-SL-2	8-SGI-2	8-SLS-2
			8-DT-2	8-SGF-2	8-DTS-2
			—	8-ADT-2	—
 <p>7/16"</p>	53%	Bearing bars spaced at 7/16" on center and cross bars at 4" or 2" on center. Types 7-4 and 7-2 comply with ADA spacing requirements and are popular for applications in the public right of way. When specified with 3/16" thick bearing bars, 7-4 and 7-2 gratings have a net 1/4" clear opening between the bearing bars and commonly reject intrusion by high heeled shoes.	7-W-4	7-SG-4	7-WS-4
			7-SL-4	7-SGI-4	7-SLS-4
			7-DT-4	7-SGF-4	7-DTS-4
			—	7-ADT-4	—
 <p>7/16"</p>	49%		7-W-2	7-SG-2	7-WS-2
			7-SL-2	7-SGI-2	7-SLS-2
			7-DT-2	7-SGF-2	7-DTS-2
			—	7-ADT-2	—

## How to Specify Metal Bar Grating

1. Select type of alloy (Steel, Aluminum, or Stainless Steel)
2. Select construction method (welded, swaged, or dovetail)
3. Select bearing bar size (height and thickness)
4. Select surface option (plain, serrated, or slip resistant applied grit)
5. Specify banded ends (strongly recommended)
6. Specify finish
7. Specify hold down clips if required

For additional load table information click link: [Metal Bar Grating](#)



## Steel Bar Grating

Steel bar grating is manufactured from ASTM A-1011 mild carbon steel and is available in three distinct products: type "W" welded bar grating, type "SL" swage locked grating, and type "DT" dovetail pressure locked grating.

All products are available with bearing bar spacing ranging from 19/16"

(1-3/16") to 7/16" on center and cross bars at either 4" or 2" on center.

Products are designed to service applications ranging from light pedestrian traffic to heavy duty vehicular loads. Finish options include bare steel, painted, hot dip galvanized, or specialty coatings.

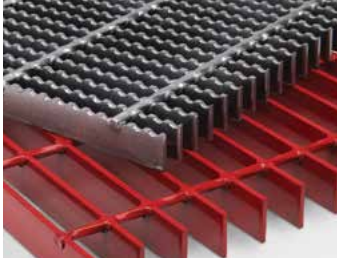

Type "W" Welded Grating



Type "SL" Swage Locked Grating



Type "DT" Dovetail Pressure Locked Grating

For additional load table information click link: [Steel Bar Grating](#)

### 19 SPACE (1-3/16") STEEL GRATING LOAD TABLE

Use this table when evaluating spans and loads of the following types of steel grating: **19-W-4, 19-W-2, 19-SL-4, 19-SL-2, 19-DT-4, 19-DT-2**

Bearing Bar Size (inches)	Approx. Weight psf	Max. Ped. Span	Sec. Prop. Sx in <sup>3</sup> / Ix in <sup>4</sup>	Unsupported Span																			
				2'-0"	2'-6"	3'-0"	3'-6"	4'-0"	4'-6"	5'-0"	5'-6"	6'-0"	6'-6"	7'-0"	8'-0"	9'-0"							
3/4 x 1/8	3.9	3'-5"	0.118 0.044	U	355	227	158	116	89	70	All loads and deflections are theoretical and based upon the gross sections of the bearing bars, using a fiber stress of 18,000 psi.												
				D	0.099	0.155	0.223	0.304	0.397	0.503	The values are not intended to be absolute since the actual load capacity will be affected by the slight variations in mill and manufacturing tolerances.												
				C	355	284	237	203	178	158	Grating for spans to the left of the heavy line have a deflection ≤ 1/4" for uniform loads of 100 psf.												
				D	0.079	0.124	0.179	0.243	0.318	0.402	85	213	U = uniform load in pounds/sq. ft. C = concentrated load in pounds/ft. of grating width D = deflection in inches										
3/4 x 3/16	5.6	3'-10"	0.178 0.067	U	533	341	237	174	133	105	85	The values are not intended to be absolute since the actual load capacity will be affected by the slight variations in mill and manufacturing tolerances.											
				D	0.099	0.155	0.223	0.304	0.397	0.503	0.621	213	Grating for spans to the left of the heavy line have a deflection ≤ 1/4" for uniform loads of 100 psf.										
				C	533	426	355	305	266	237	213	84	230	U = uniform load in pounds/sq. ft. C = concentrated load in pounds/ft. of grating width D = deflection in inches									
				D	0.079	0.124	0.179	0.243	0.318	0.402	0.497	101	253										
1 x 1/8	5.0	4'-3"	0.211 0.105	U	632	404	281	206	158	125	101	The values are not intended to be absolute since the actual load capacity will be affected by the slight variations in mill and manufacturing tolerances.											
				D	0.074	0.116	0.168	0.228	0.298	0.377	0.466	0.563	230	Grating for spans to the left of the heavy line have a deflection ≤ 1/4" for uniform loads of 100 psf.									
				C	632	505	421	361	316	281	253	230	105	U = uniform load in pounds/sq. ft. C = concentrated load in pounds/ft. of grating width D = deflection in inches									
				D	0.060	0.093	0.134	0.182	0.238	0.302	0.372	0.451	125										
1 x 3/16	7.2	4'-9"	0.316 0.158	U	947	606	421	309	237	187	152	125	105	The values are not intended to be absolute since the actual load capacity will be affected by the slight variations in mill and manufacturing tolerances.									
				D	0.074	0.116	0.168	0.228	0.298	0.377	0.466	0.563	0.670	Grating for spans to the left of the heavy line have a deflection ≤ 1/4" for uniform loads of 100 psf.									
				C	947	758	632	541	474	421	379	345	316	110	93	U = uniform load in pounds/sq. ft. C = concentrated load in pounds/ft. of grating width D = deflection in inches							
				D	0.060	0.093	0.134	0.182	0.238	0.302	0.372	0.451	0.536	0.629									
1-1/4 x 1/8	6.1	5'-1"	0.329 0.206	U	987	632	439	322	247	195	158	131	110	93	The values are not intended to be absolute since the actual load capacity will be affected by the slight variations in mill and manufacturing tolerances.								
				D	0.060	0.093	0.134	0.182	0.238	0.302	0.372	0.451	0.536	0.629	Grating for spans to the left of the heavy line have a deflection ≤ 1/4" for uniform loads of 100 psf.								
				C	987	790	658	564	493	439	395	359	329	304	121	133	U = uniform load in pounds/sq. ft. C = concentrated load in pounds/ft. of grating width D = deflection in inches						
				D	0.048	0.074	0.107	0.146	0.191	0.241	0.298	0.360	0.429	0.504	0.584								
1-1/4 x 3/16	8.9	5'-7"	0.493 0.308	U	1,480	947	658	483	370	292	237	196	165	140	121	The values are not intended to be absolute since the actual load capacity will be affected by the slight variations in mill and manufacturing tolerances.							
				D	0.060	0.093	0.134	0.182	0.238	0.302	0.372	0.451	0.536	0.629	0.730	Grating for spans to the left of the heavy line have a deflection ≤ 1/4" for uniform loads of 100 psf.							
				C	1,480	1,184	987	846	740	658	592	538	493	456	423	423	116	U = uniform load in pounds/sq. ft. C = concentrated load in pounds/ft. of grating width D = deflection in inches					
				D	0.048	0.074	0.107	0.146	0.191	0.241	0.298	0.360	0.429	0.504	0.584								
1-1/2 x 1/8	7.2	5'-10"	0.474 0.355	U	1,421	910	632	464	355	281	227	188	158	135	116	The values are not intended to be absolute since the actual load capacity will be affected by the slight variations in mill and manufacturing tolerances.							
				D	0.050	0.078	0.112	0.152	0.199	0.251	0.310	0.376	0.447	0.524	0.608	Grating for spans to the left of the heavy line have a deflection ≤ 1/4" for uniform loads of 100 psf.							
				C	1,421	1,137	947	812	711	632	568	517	474	437	406	116	133	U = uniform load in pounds/sq. ft. C = concentrated load in pounds/ft. of grating width D = deflection in inches					
				D	0.040	0.062	0.089	0.122	0.159	0.201	0.248	0.300	0.358	0.420	0.487								
1-1/2 x 3/16	10.7	6'-5"	0.711 0.533	U	2,132	1,364	947	696	533	421	341	282	237	202	174	133	The values are not intended to be absolute since the actual load capacity will be affected by the slight variations in mill and manufacturing tolerances.						
				D	0.050	0.078	0.112	0.152	0.199	0.251	0.310	0.376	0.447	0.524	0.608	Grating for spans to the left of the heavy line have a deflection ≤ 1/4" for uniform loads of 100 psf.							
				C	2,132	1,705	1,421	1,218	1,066	947	853	775	711	656	609	533	116	133	U = uniform load in pounds/sq. ft. C = concentrated load in pounds/ft. of grating width D = deflection in inches				
				D	0.040	0.062	0.089	0.122	0.159	0.201	0.248	0.300	0.358	0.420	0.487	0.566							
1-3/4 x 1/8	8.5	6'-6"	0.645 0.564	U	1,934	1,238	860	632	484	382	310	256	215	183	158	121	96	The values are not intended to be absolute since the actual load capacity will be affected by the slight variations in mill and manufacturing tolerances.					
				D	0.043	0.067	0.096	0.130	0.170	0.215	0.266	0.322	0.383	0.450	0.521	0.601	Grating for spans to the left of the heavy line have a deflection ≤ 1/4" for uniform loads of 100 psf.						
				C	1,934	1,547	1,290	1,105	967	860	774	703	645	595	553	484	430	116	133	U = uniform load in pounds/sq. ft. C = concentrated load in pounds/ft. of grating width D = deflection in inches			
				D	0.034	0.053	0.077	0.104	0.136	0.172	0.213	0.257	0.306	0.360	0.417	0.477							
1-3/4 x 3/16	12.3	7'-3"	0.967 0.846	U	2,901	1,857	1,290	947	725	573	464	384	322	275	237	181	143	The values are not intended to be absolute since the actual load capacity will be affected by the slight variations in mill and manufacturing tolerances.					
				D	0.043	0.067	0.096	0.130	0.170	0.215	0.266	0.322	0.383	0.450	0.521	0.601	Grating for spans to the left of the heavy line have a deflection ≤ 1/4" for uniform loads of 100 psf.						
				C	2,901	2,321	1,934	1,658	1,451	1,290	1,161	1,055	967	893	829	725	645	116	133	U = uniform load in pounds/sq. ft. C = concentrated load in pounds/ft. of grating width D = deflection in inches			
				D	0.034	0.053	0.077	0.104	0.136	0.172	0.213	0.257	0.306	0.360	0.417	0.477							
2 x 1/8	9.6	7'-4"	0.842 0.842	U	2,526	1,617	1,123	825	632	499	404	334	281	239	206	158	125	The values are not intended to be absolute since the actual load capacity will be affected by the slight variations in mill and manufacturing tolerances.					
				D	0.037	0.058	0.084	0.114	0.149	0.189	0.233	0.282	0.335	0.393	0.456	0.524	Grating for spans to the left of the heavy line have a deflection ≤ 1/4" for uniform loads of 100 psf.						
				C	2,526	2,021	1,684	1,444	1,263	1,123	1,011	919	842	777	722	632	561	116	133	U = uniform load in pounds/sq. ft. C = concentrated load in pounds/ft. of grating width D = deflection in inches			
				D	0.030	0.047	0.067	0.091	0.119	0.151	0.186	0.225	0.268	0.315	0.365	0.417							
2 x 3/16	13.9	8'-0"	1.263 1.263	U	3,790	2,425	1,684	1,237	947	749	606	501	421	359	309	237	187	The values are not intended to be absolute since the actual load capacity will be affected by the slight variations in mill and manufacturing tolerances.					
				D	0.037	0.058	0.084	0.114	0.149	0.189	0.233	0.282	0.335	0.393	0.456	0.524	Grating for spans to the left of the heavy line have a deflection ≤ 1/4" for uniform loads of 100 psf.						
				C	3,790	3,032	2,526	2,165	1,895	1,684	1,516	1,378	1,263	1,166	1,083	947	842	116	133	U = uniform load in pounds/sq. ft. C = concentrated load in pounds/ft. of grating width D = deflection in inches			
				D	0.030	0.047	0.067	0.091	0.119	0.151	0.186	0.225	0.268	0.315	0.365	0.417							
2-1/4 x 3/16	15.6	8'-9"	1.599 1.799	U	4,796	3,070	2,132	1,566	1,199	947	767	634	533	454	392	300	237	The values are not intended to be absolute since the actual load capacity will be affected by the slight variations in mill and manufacturing tolerances.					
				D	0.033	0.052	0.074	0.101	0.132	0.168	0.207	0.250	0.298	0.350	0.406	0.463	Grating for spans to the left of the heavy line have a deflection ≤ 1/4" for uniform loads of 100 psf.						
				C	4,796	3,837	3,197	2,741	2,398	2,132	1,918	1,744	1,599	1,476	1,370	1,199	1,066	116	133	U = uniform load in pounds/sq. ft. C = concentrated load in pounds/ft. of grating width D = deflection in inches			
				D	0.026	0.041	0.060	0.081	0.106	0.134	0.166	0.200	0.238	0.280	0.324	0.374							
2-1/2 x 3/16	17.2	9'-5"	1.974 2.467	U	5,921	3,790	2,632	1,933	1,480	1,170	947	783	658	561	483	370	292	The values are not intended to be absolute since the actual load capacity will be affected by the slight variations in mill and manufacturing tolerances.					
				D	0.030	0.047	0.067	0.091	0.119	0.151	0.186	0.225	0.268	0.315	0.365	0.417	Grating for spans to the left of the heavy line have a deflection ≤ 1/4" for uniform loads of 100 psf.						
				C	5,921	4,737	3,947	3,384	2,961	2,632	2,368	2,153	1,974	1,822	1,692	1,480	1,316	116	133	U = uniform load in pounds/sq. ft. C = concentrated load in pounds/ft. of grating width D = deflection in inches			
				D	0.024	0.037	0.054	0.073	0.095	0.121	0.149	0.180	0.215	0.252	0.292	0.381							

# METAL BAR GRATING

## Aluminum Bar Grating

Aluminum bar grating is lightweight, corrosion resistant, and fully recyclable. With an unmatched strength-to-weight ratio, these products are ideal for both industrial and architectural applications.

Manufactured from ASTM B221, 6063, or 6061 alloy, aluminum grating is available in four distinct product types. Bearing bar spacings range

from 19/16" (1-3/16") to 7/16" on center with cross bars at 4" or 2" on center.

Aluminum products are available in standard mill finish. Optional anodizing, chemical cleaning, or powder coated finishes are available for highly corrosive or architectural applications.

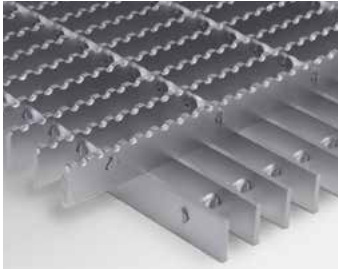

Type "SG" Swage Locked Grating



Type "SGI" Swage Locked I-Bar Grating

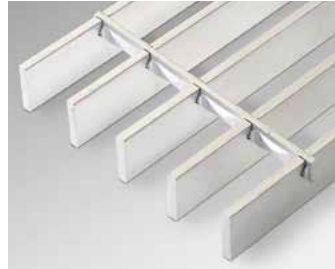

Type "SGF" Swaged Flush-Top Grating



Type "ADT" Dovetail Pressure Locked Grating

### 19 SPACE (1-3/16") ALUMINUM GRATING LOAD TABLE

Use this table when evaluating spans and loads of the following types of aluminum grating:

**19-SG-4, 19-SG-2, 19-SGI-4, 19-SGI-2, 19-SGF-4, 19-SGF-2, 19-ADT-4, 19-ADT-2**

Bearing Bar Size (inches)	Approx. Weight psf	Max. Ped. Span	Sec. Prop. Sx in <sup>3</sup> lx in <sup>4</sup>	Unsupported Span																	
				2'-0"	2'-6"	3'-0"	3'-6"	4'-0"	4'-6"	5'-0"	5'-6"	6'-0"	6'-6"	7'-0"	8'-0"						
3/4 x 3/16	1.9	2'-11"	0.178 0.067	U	355	227	158	116													
				D	0.192	0.300	0.432	0.588													
				C	355	284	237	203													
				D	0.154	0.240	0.346	0.470													
3/4" I-Bar	1.7	2'-11"	0.178 0.067	U	421	270	187	138													
				D	0.144	0.225	0.324	0.441	105												
				C	421	337	281	241	211												
				D	0.115	0.180	0.259	0.353	0.461												
1 x 1/8	1.7	3'-3"	0.211 0.105	U	632	404	281	206	158	125											
				D	0.144	0.225	0.324	0.441	0.576												
				C	421	337	281	241	211												
				D	0.115	0.180	0.259	0.353	0.461												
1 x 3/16	2.5	3'-8"	0.316 0.158	U	658	421	292	215	165	130											
				D	0.144	0.225	0.324	0.441	0.576												
				C	632	505	421	361	316												
				D	0.115	0.180	0.259	0.353	0.461												
1" I-Bar	2.0	3'-8"	0.316 0.158	U	658	421	292	215	165	130											
				D	0.144	0.225	0.324	0.441	0.576												
				C	632	505	421	361	316												
				D	0.115	0.180	0.259	0.353	0.461												
1-1/4 x 1/8	2.1	3'-11"	0.329 0.206	U	658	421	292	215	165	130											
				D	0.115	0.180	0.259	0.353	0.461												
				C	658	526	439	376	329												
				D	0.092	0.144	0.207	0.282	0.369												
1-1/4 x 3/16	3.1	4'-4"	0.493 0.308	U	987	632	439	322	247	195											
				D	0.115	0.180	0.259	0.353	0.461												
				C	987	790	658	564	493												
				D	0.092	0.144	0.207	0.282	0.369												
1-1/4" I-Bar	2.4	4'-4"	0.493 0.308	U	947	606	421	309	237	187											
				D	0.096	0.150	0.216	0.294	0.384												
				C	947	758	632	541	474												
				D	0.077	0.120	0.173	0.235	0.307												
1-1/2 x 1/8	2.5	4'-5"	0.474 0.355	U	1,421	910	632	464	355	281											
				D	0.096	0.150	0.216	0.294	0.384												
				C	1,421	1,137	947	812	711												
				D	0.077	0.120	0.173	0.235	0.307												
1-1/2 x 3/16	3.7	4'-11"	0.711 0.533	U	1,290	825	573	421	322	255											
				D	0.082	0.129	0.185	0.252	0.329												
				C	1,290	1,032	860	737	645												
				D	0.066	0.103	0.148	0.202	0.263												
1-1/2" I-Bar	2.7	4'-11"	0.711 0.533	U	1,421	910	632	464	355	281											
				D	0.096	0.150	0.216	0.294	0.384												
				C	1,421	1,137	947	812	711												
				D	0.077	0.120	0.173	0.235	0.307												
1-3/4 x 1/8	2.9	5'-0"	0.645 0.564	U	1,934	1,238	860	632	484	382											
				D	0.082	0.129	0.185	0.252	0.329												
				C	1,934	1,547	1,290	1,105	967												
				D	0.066	0.103	0.148	0.202	0.263												
1-3/4" I-Bar	3.1	5'-6"	0.967 0.846	U	1,684	1,078	749	550	421	333											
				D	0.072	0.113	0.162	0.221	0.288												
				C	1,684	1,347	1,123	962	842												
				D	0.058	0.090	0.130	0.176	0.230												
2 x 1/8	3.3	5'-6"	0.842	U	2,526	1,617	1,123	825	632	499											
				D	0.072	0.113	0.162	0.221	0.288												
				C	1,684	1,347	1,123	962	842												
				D	0.058	0.090	0.130	0.176	0.230												
2 x 3/16	4.8	6'-1"	1.263 1.263	U	3,197	2,046	1,421	1,044	799	632											
				D	0.058	0.090	0.130	0.176	0.230												
				C	3,197	2,046	1,421	1,044	799												
				D	0.058	0.090	0.130	0.176	0.230												
2" I-Bar	3.5	6'-1"	1.263 1.263	U	3,947	2,526	1,754	1,289	987	780											
				D	0.051	0.080	0.115	0.157	0.205												
				C	3,947	2,526	1,754	1,289	987												
				D	0.051	0.080	0.115	0.157	0.205												
2-1/4 x 3/16	5.4	6'-8"	1.599 1.799	U	3,947	2,526	1,754	1,289	987	780											
				D	0.051	0.080	0.115	0.157	0.205												
				C	3,947	2,526	1,754	1,289	987												
				D	0.051	0.080	0.115	0.157	0.205												
2-1/4" I-Bar	3.8	6'-8"	1.599 1.799	U	3,947	2,526	1,754	1,289	987	780											
				D	0.051	0.080	0.115	0.157	0.205												
				C	3,947	2,526	1,754	1,289	987												
				D	0.051	0.080	0.115	0.157	0.205												
2-1/2 x 3/16	5.9	7'-3"	1.974 2.467	U	3,947	2,526	1,754	1,289	987	780											
				D	0.058	0.090	0.130	0.176	0.230												
				C	3,947	2,526	1,754	1,289	987												
				D	0.058	0.090	0.130	0.176	0.230												
2-1/2" I-Bar	4.2	7'-3"	1.974 2.467	U	3,947	2,526	1,754	1,289	987	780											
				D	0.046	0.072	0.104	0.141	0.184												
				C	3,947	2,526	1,754	1,289	987												
				D	0.046	0.072	0.104	0.141	0.184												

All loads and deflections are theoretical and based upon the gross sections of the bearing bars, using a fiber stress of 12,000 psi.

The values are not intended to be absolute since the actual load capacity will be affected by the slight



## Stainless Steel Bar Grating

Manufactured from alloy types 304, 304L, 316, and 316L, stainless steel gratings are ideal for sanitary or highly corrosive environments and architectural applications.

Available in three different methods of construction: type "WS" welded, type "SLS" swage locked, and type "DTS" dovetail. Stainless steel gratings are produced with bearing bar spacings ranging from 19/16" (1-3/16") to 7/16" on center with cross bars at 4" or 2" on center.



Type "WS" Welded Grating



Type "SL" Swage Locked Grating



Type "DTS" Dovetail Pressure Locked Grating

For additional load table information click link: [Stainless Steel Bar Grating](#)

### 19 SPACE (1-3/16") STAINLESS STEEL GRATING LOAD TABLE

Use this table when evaluating spans and loads of the following types of stainless steel grating:

**19-WS-4, 19-WS-2, 19-SLS-4, 19-SLS-2, 19-DTS-4, 19-DTS-2**

Bearing Bar Size (inches)	Approx. Weight psf	Max. Ped. Span	Sec. Prop. Sx in <sup>3</sup> Ix in <sup>4</sup>	Unsupported Span														
				2'-0"	2'-6"	3'-0"	3'-6"	4'-0"	4'-6"	5'-0"	5'-6"	6'-0"	6'-6"	7'-0"	8'-0"	9'-0"		
3/4 x 1/8	3.9	3'-5"	0.118 0.044	U	395	253	175	129	99	78	All loads and deflections are theoretical and based upon the gross sections of the bearing bars, using a fiber stress of 20,000 psi.  The values are not intended to be absolute since the actual load capacity will be affected by the slight variations in mill and manufacturing tolerances.  Grating for spans to the left of the heavy line have a deflection ≤ 1/4" for uniform loads of 100 psf.  U = uniform load in pounds/sq. ft. C = concentrated load in pounds/ft. of grating width D = deflection in inches							
				D	0.114	0.179	0.257	0.350	0.457	0.579								
				C	395	316	263	226	197	175								
				D	0.091	0.143	0.206	0.280	0.366	0.463								
3/4 x 3/16	5.6	3'-9"	0.178 0.067	U	592	379	263	193	148	117	95	The values are not intended to be absolute since the actual load capacity will be affected by the slight variations in mill and manufacturing tolerances.  Grating for spans to the left of the heavy line have a deflection ≤ 1/4" for uniform loads of 100 psf.  U = uniform load in pounds/sq. ft. C = concentrated load in pounds/ft. of grating width D = deflection in inches						
				D	0.114	0.179	0.257	0.350	0.457	0.579	0.714							
				C	592	474	395	338	296	263	237							
				D	0.091	0.143	0.206	0.280	0.366	0.463	0.571							
1 x 1/8	5.0	4'-3"	0.211 0.105	U	702	449	312	229	175	139	112	93	The values are not intended to be absolute since the actual load capacity will be affected by the slight variations in mill and manufacturing tolerances.  Grating for spans to the left of the heavy line have a deflection ≤ 1/4" for uniform loads of 100 psf.  U = uniform load in pounds/sq. ft. C = concentrated load in pounds/ft. of grating width D = deflection in inches					
				D	0.086	0.134	0.193	0.263	0.343	0.434	0.536	0.648						
				C	702	561	468	401	351	312	281	255						
				D	0.069	0.107	0.154	0.210	0.274	0.347	0.429	0.519						
1 x 3/16	7.2	4'-8"	0.316 0.158	U	1,053	674	468	344	263	208	168	139	117	The values are not intended to be absolute since the actual load capacity will be affected by the slight variations in mill and manufacturing tolerances.  Grating for spans to the left of the heavy line have a deflection ≤ 1/4" for uniform loads of 100 psf.  U = uniform load in pounds/sq. ft. C = concentrated load in pounds/ft. of grating width D = deflection in inches				
				D	0.086	0.134	0.193	0.263	0.343	0.434	0.536	0.648	0.771					
				C	1,053	842	702	602	526	468	421	383	351					
				D	0.069	0.107	0.154	0.210	0.274	0.347	0.429	0.519	0.617					
1-1/4 x 1/8	6.1	5'-0"	0.329 0.206	U	1,097	702	487	358	274	217	175	145	122	104	The values are not intended to be absolute since the actual load capacity will be affected by the slight variations in mill and manufacturing tolerances.  Grating for spans to the left of the heavy line have a deflection ≤ 1/4" for uniform loads of 100 psf.  U = uniform load in pounds/sq. ft. C = concentrated load in pounds/ft. of grating width D = deflection in inches			
				D	0.069	0.107	0.154	0.210	0.274	0.347	0.429	0.519	0.617	0.724				
				C	1,097	877	731	627	548	487	439	399	366	337				
				D	0.055	0.086	0.123	0.168	0.219	0.278	0.343	0.415	0.494	0.579				
1-1/4 x 3/16	8.9	5'-6"	0.493 0.308	U	1,645	1,053	731	537	411	325	263	218	183	156	134	The values are not intended to be absolute since the actual load capacity will be affected by the slight variations in mill and manufacturing tolerances.  Grating for spans to the left of the heavy line have a deflection ≤ 1/4" for uniform loads of 100 psf.  U = uniform load in pounds/sq. ft. C = concentrated load in pounds/ft. of grating width D = deflection in inches		
				D	0.069	0.107	0.154	0.210	0.274	0.347	0.429	0.519	0.617	0.724	0.840			
				C	1,645	1,316	1,097	940	822	731	658	598	548	506	470			
				D	0.055	0.086	0.123	0.168	0.219	0.278	0.343	0.415	0.494	0.579	0.672			
1-1/2 x 1/8	7.2	5'-9"	0.474 0.355	U	1,579	1,011	702	516	395	312	253	209	175	150	129	The values are not intended to be absolute since the actual load capacity will be affected by the slight variations in mill and manufacturing tolerances.  Grating for spans to the left of the heavy line have a deflection ≤ 1/4" for uniform loads of 100 psf.  U = uniform load in pounds/sq. ft. C = concentrated load in pounds/ft. of grating width D = deflection in inches		
				D	0.057	0.089	0.129	0.175	0.229	0.289	0.357	0.432	0.514	0.604	0.700			
				C	1,579	1,263	1,053	902	790	702	632	574	526	486	451			
				D	0.046	0.071	0.103	0.140	0.183	0.231	0.286	0.346	0.411	0.483	0.560			
1-1/2 x 3/16	10.7	6'-4"	0.711 0.533	U	2,368	1,516	1,053	773	592	468	379	313	263	224	193	148	The values are not intended to be absolute since the actual load capacity will be affected by the slight variations in mill and manufacturing tolerances.  Grating for spans to the left of the heavy line have a deflection ≤ 1/4" for uniform loads of 100 psf.  U = uniform load in pounds/sq. ft. C = concentrated load in pounds/ft. of grating width D = deflection in inches	
				D	0.057	0.089	0.129	0.175	0.229	0.289	0.357	0.432	0.514	0.604	0.700	0.914		
				C	2,368	1,895	1,579	1,353	1,184	1,053	947	861	790	729	677	592		
				D	0.046	0.071	0.103	0.140	0.183	0.231	0.286	0.346	0.411	0.483	0.560	0.731		
1-3/4 x 1/8	8.5	6'-5"	0.645 0.564	U	2,149	1,375	955	702	537	425	344	284	239	204	175	134	106	The values are not intended to be absolute since the actual load capacity will be affected by the slight variations in mill and manufacturing tolerances.  Grating for spans to the left of the heavy line have a deflection ≤ 1/4" for uniform loads of 100 psf.  U = uniform load in pounds/sq. ft. C = concentrated load in pounds/ft. of grating width D = deflection in inches
				D	0.049	0.077	0.110	0.150	0.196	0.248	0.306	0.370	0.441	0.517	0.600	0.784	0.992	
				C	2,149	1,719	1,433	1,228	1,075	955	860	782	716	661	614	537	478	
				D	0.039	0.061	0.088	0.120	0.157	0.198	0.245	0.296	0.353	0.414	0.480	0.627	0.793	
1-3/4 x 3/16	12.3	7'-2"	0.967 0.846	U	3,224	2,063	1,433	1,053	806	637	516	426	358	305	263	202	159	The values are not intended to be absolute since the actual load capacity will be affected by the slight variations in mill and manufacturing tolerances.  Grating for spans to the left of the heavy line have a deflection ≤ 1/4" for uniform loads of 100 psf.  U = uniform load in pounds/sq. ft. C = concentrated load in pounds/ft. of grating width D = deflection in inches
				D	0.049	0.077	0.110	0.150	0.196	0.248	0.306	0.370	0.441	0.517	0.600	0.784	0.992	
				C	3,224	2,579	2,149	1,842	1,612	1,433	1,290	1,172	1,075	992	921	806	716	
				D	0.039	0.061	0.088	0.120	0.157	0.198	0.245	0.296	0.353	0.414	0.480	0.627	0.793	
2 x 1/8	9.6	7'-1"	0.842 0.842	U	2,807	1,797	1,248	917	702	555	449	371	312	266	229	175	139	The values are not intended to be absolute since the actual load capacity will be affected by the slight variations in mill and manufacturing tolerances.  Grating for spans to the left of the heavy line have a deflection ≤ 1/4" for uniform loads of 100 psf.  U = uniform load in pounds/sq. ft. C = concentrated load in pounds/ft. of grating width D = deflection in inches
				D	0.043	0.067	0.096	0.131	0.171	0.217	0.268	0.324	0.386	0.453	0.525	0.686	0.868	
				C	2,807	2,246	1,871	1,604	1,404	1,248	1,123	1,021	936	864	802	702	624	
				D	0.034	0.054	0.077	0.105	0.137	0.174	0.214	0.259	0.309	0.362	0.420	0.549	0.694	
2 x 3/16	13.9	7'-11"	1.263 1.263	U	4,211	2,695	1,871	1,375	1,053	832	674	557	468	399	344	263	208	The values are not intended to be absolute since the actual load capacity will be affected by the slight variations in mill and manufacturing tolerances.  Grating for spans to the left of the heavy line have a deflection ≤ 1/4" for uniform loads of 100 psf.  U = uniform load in pounds/sq. ft. C = concentrated load in pounds/ft. of grating width D = deflection in inches
				D	0.043	0.067	0.096	0.131	0.171	0.217	0.268	0.324	0.386	0.453	0.525	0.686	0.868	
				C	4,211	3,368	2,807	2,406	2,105	1,871	1,684	1,531	1,404	1,296	1,203	1,053	936	
				D	0.034	0.054	0.077	0.105	0.137	0.174	0.214	0.259	0.309	0.362	0.420	0.549	0.694	
2-1/4 x 3/16	15.6	8'-8"	1.599 1.799	U	5,329	3,411	2,368	1,740	1,332	1,053	853	705	592	505	435	333	263	The values are not intended to be absolute since the actual load capacity will be affected by the slight variations in mill and manufacturing tolerances.  Grating for spans to the left of the heavy line have a deflection ≤ 1/4" for uniform loads of 100 psf.  U = uniform load in pounds/sq. ft. C = concentrated load in pounds/ft. of grating width D = deflection in inches
				D	0.038	0.060	0.086	0.117	0.152	0.193	0.238	0.288	0.343	0.402	0.467	0.610	0.771	
				C	5,329	4,263	3,553	3,045	2,665	2,368	2,132	1,938	1,776	1,640	1,523	1,332	1,184	
				D	0.030	0.048	0.069	0.093	0.122	0.154	0.190	0.230	0.274	0.322	0.373	0.488	0.617	
2-1/2 x 3/16	17.2	9'-4"	1.974 2.467	U	6,579	4,211	2,924	2,148	1,645	1,300	1,053	870	731	622	537	411	325	The values are not intended to be absolute since the actual load capacity will be affected by the slight variations in mill and manufacturing tolerances.  Grating for spans to the left of the heavy line have a deflection ≤ 1/4" for uniform loads of 100 psf.  U = uniform load in pounds/sq. ft. C = concentrated load in pounds/ft. of grating width D = deflection in inches
				D	0.034	0.054	0.077	0.105	0.137	0.174	0.214	0.259	0.309	0.362	0.420	0.549	0.694	
				C	6,579	5,263	4,386	3,759	3,290	2,924	2,632	2,392	2,193	2,024	1,880	1,645	1,462	
				D	0.027	0.043	0.062	0.084	0.110	0.139	0.171	0.207	0.247	0.290	0.336	0.439	0.555	

## BAR GRATING STAIR TREADS

Fabricated bar grating stair treads are available in the full range of metal bar grating offerings. Stair treads are fabricated with a standard 1-1/4" visibly defined nosing, or an optional 2" wide nosing for applications subject to California Title 24 and the California Building Code.

### Steel Bar Grating Stair Treads

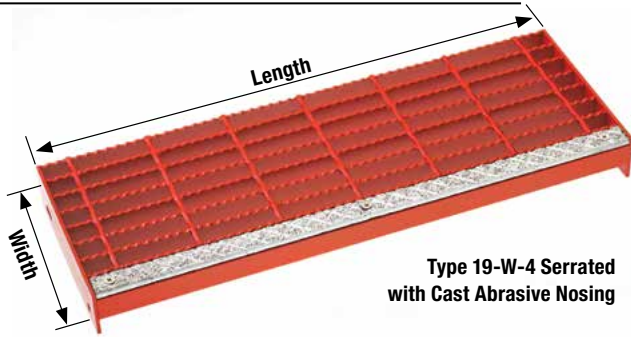

Type 19-W-4 Serrated with Cast Abrasive Nosing

### Aluminum Bar Grating Stair Treads



Type 19-SG-4 with Corrugated Aluminum Nosing

### Stainless Steel Bar Grating Stair Treads

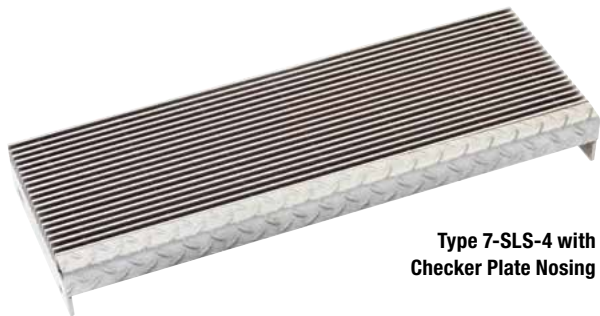

Type 7-SLS-4 with Checker Plate Nosing

### Nosing Options



#### Checker Plate

Carbon and Stainless Steel only. Welded to grating and carrier plates/angles.



#### Cast Abrasive

Carbon, stainless, and aluminum treads. Mechanically fastened to welded mounting angle.



#### FRP

Carbon, stainless, and aluminum treads. Mechanically fastened to welded mounting angle.



#### OnGrip/Algrip

Carbon, stainless, and aluminum treads. Welded to grating and carrier plates/angles.



#### Corrugated Aluminum

Aluminum treads only. Welded to grating and carrier plates/angles.

Nosing available in standard 1-1/4" width, with optional 2" widths available when specified at time of ordering.

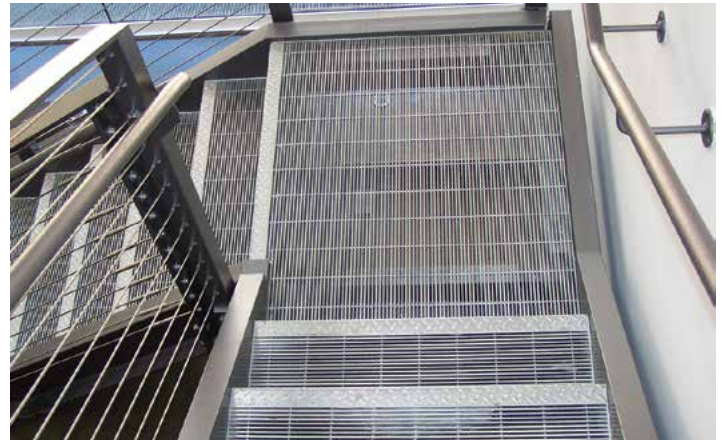

For additional load table information click link: [Bar Grating Stair Treads](#)

### Carrier Plates & Angles

#### Carrier Plates

Recommended for use with 19, 15, and 11 spaced gratings.

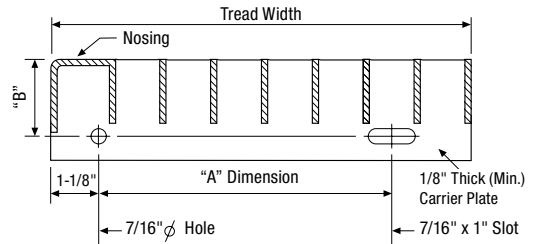

#### Carrier Angles

Recommended for use with 8 and 7 spaced gratings.

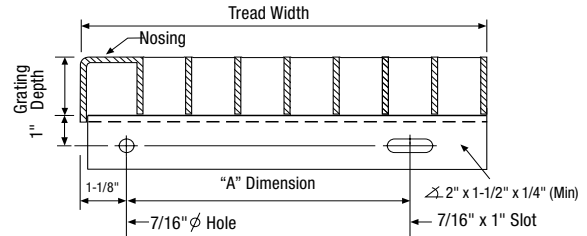



## ALUMINUM PLANK GRATING

Aluminum plank grating is extruded in 6" and 3" wide sections that measure up to 26' long. Available with a striated walking surface that is solid or punched in a variety of patterns. The solid walking surface aids in odor containment and restricts the passage of debris; the punched hole patterns are available to allow the passage of air, light, heat, or moisture.

### Punch Patterns

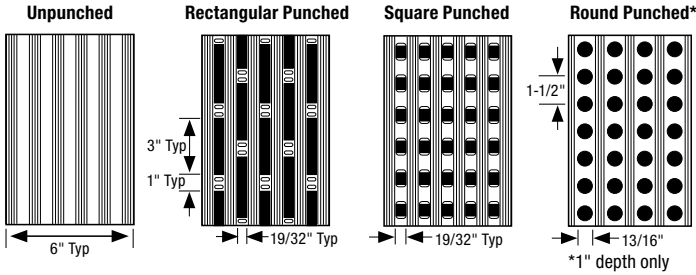

### ADA Conforming Punch Patterns

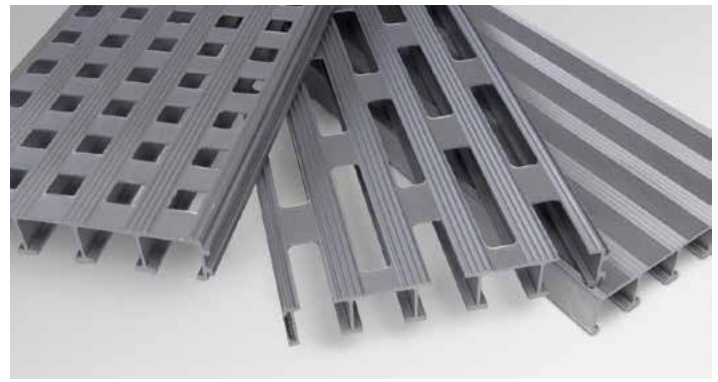
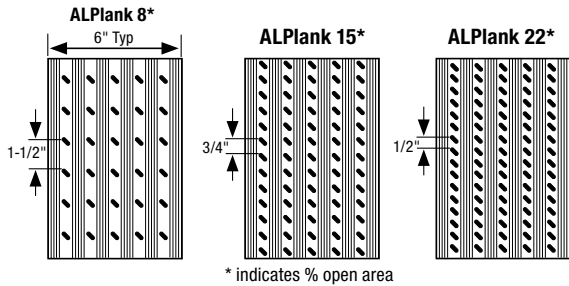

### Plank Options

#### Heavy Duty – Slide Lock

Heavy duty aluminum planks with male-female interlocking side channels. Planks are available 6" wide in depths ranging from 1" to 2-1/2".

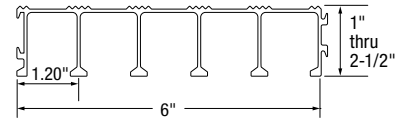

#### Heavy Duty – Plain Sides

Heavy duty aluminum plank is available with plain sides in depths ranging from 3/4" to 2-1/2".

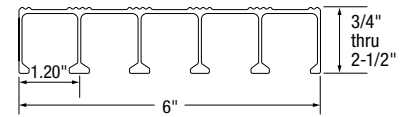

#### Heavy Duty – Snap Lock

Male-female interlocking side channels snap together into modular panels with minimal welding. Available in 6" wide planks, 1" deep.

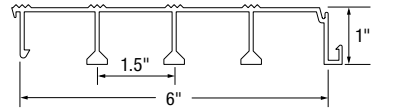

#### Light Series – Plain Sides

Available in 6" wide, plain side planks only.

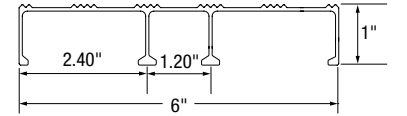

## RIVETED BAR GRATING

Riveted gratings are the oldest form of grating and offer superior resistance to impact. Ideal for applications where high strength and stiffness are required. Manufactured by cold press riveting straight bearing bars to crimped rectangular flat bars, riveted gratings are available in carbon steel, 6000 series aluminum, and 300 series stainless steel. Bearing bars are spaced either 1-1/8" or 3/4" apart and the standard rivet spacing is 7 inches on center. Optional close rivet spacing of 3-1/2" on center is also available.

Standard serration includes serration of the reticuline bars which are raised slightly above the top plane of the bearing bars. Users may specify 100% serrated where both the bearing bars and cross members are provided with serration.

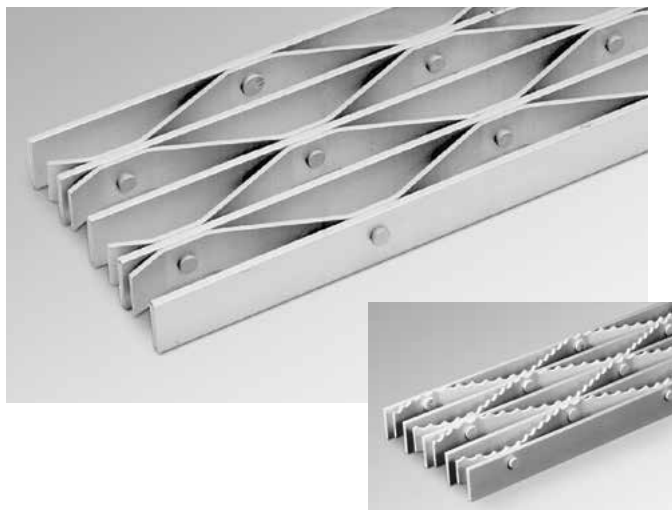

### Riveted Grating Table of Spacings Available

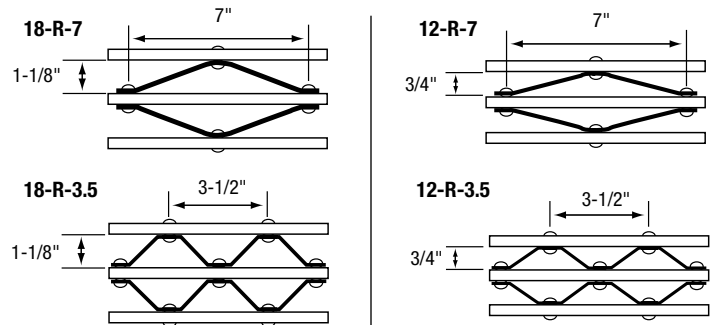

The part numbers shown above are for carbon steel riveted gratings. To specify aluminum or stainless steel products, replace the alpha character "R" with "AR" for aluminum products or "SR" for stainless steel products.

For additional information click link: [Riveted Bar Grating](#)







## HEAVY DUTY BAR GRATING

Welded heavy duty gratings are designed to service applications subject to heavy rolling and static loads such as highways, plant floors, loading docks, inlet covers, and airports. Products are available in a wide range of bar sizes and spacings to accommodate conditions ranging from small forklift to large truck or aircraft traffic.



### Design Criteria

Vehicular loads are designed in conformance with current AASHTO specifications for classifications H-15 through H-25. Automobile and forklift loads are similarly evaluated with loads calculated and distributed in accordance with the stated "Maximum Traffic Conditions". If your application is not adequately addressed by these load conditions, please contact our Engineering Department and we will gladly assist with your specific needs.

MAXIMUM TRAFFIC CONDITIONS							
Design Load	Wheel Load (lbs) (1/2 Axle Load + 30% Impact)	Load Distribution		Design Load	Wheel Load (lbs) (1/2 Axle Load + 30% Impact)	Load Distribution	
		Parallel to Axle (1)	Perpendicular to Axle			Parallel with Axle	Perpendicular to Axle
<b>H-25</b>  <b>Truck Traffic</b> 40,000 lb Axle Load Dual Wheels Modified AASHTO H-25	26,000	2 (C)*+25"	25"	 <b>10,000 lb. Cap Lift Truck</b> 14,400 lb. Vehicle 24,400 lb. Total Load 85% Drive Axle Load  <b>5 Ton Forklift</b>	13,480	2 (C)*+11"	11"
<b>H-20</b>  <b>Truck Traffic</b> 32,000 lb Axle Load Dual Wheels Modified AASHTO H-20	20,800	2 (C)*+20"	20"	 <b>6,000 lb. Cap Lift Truck</b> 9,800 lb. Vehicle 15,800 lb. Total Load 85% Drive Axle Load  <b>3 Ton Forklift</b>	8,730	2 (C)*+7"	7"
<b>H-15</b>  <b>Truck Traffic</b> 24,000 lb Axle Load Dual Wheels Modified AASHTO H-15	15,600	2 (C)*+15"	15"	 <b>2,000 lb. Cap Lift Truck</b> 4,200 lb. Vehicle 6,200 lb. Total Load 85% Drive Axle Load  <b>1 Ton Forklift</b>	3,425	2 (C)*+4"	4"
<b>Automobile</b>  <b>Automobile Traffic</b> 6,322 lb. Vehicle 3,578 lb. Load 60% Drive Axle Load	3,861	2 (C)*+9"	9"	*C = Center-to-center spacing of bearing bars. Allowable Stress - 20,000 psi Modulus of elasticity - 29,000,000 psi			

### Materials & Spacing

Heavy duty gratings are manufactured in carbon steel and 300 series stainless steel. Carbon steel products are available bare (no finish), painted with manufacturers standard paint, or hot dip galvanized. Stainless steel products are available mill finish, commercially cleaned, or electro-polished. Below you will find a table of spacings for our most popular products.

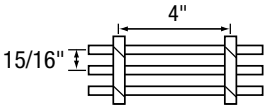
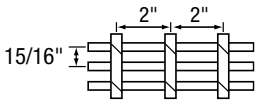
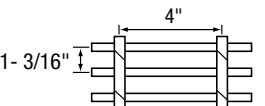
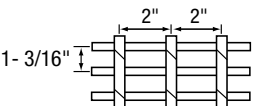
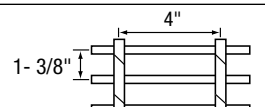
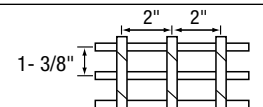
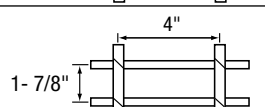
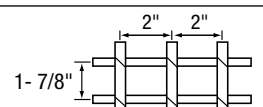
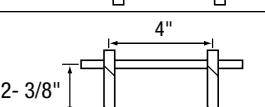
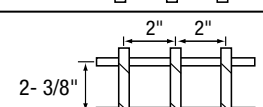
TABLE OF SPACINGS			
<b>15-W-4</b>		Bearing Bars at 15/16" O.C. Cross Bars at 4" O.C.	<b>15-W-2</b> 
<b>19-W-4</b>		Bearing Bars at 1-3/16" O.C. Cross Bars at 4" O.C.	<b>19-W-2</b> 
<b>22-W-4</b>		Bearing Bars at 1-3/8" O.C. Cross Bars at 4" O.C.	<b>22-W-2</b> 
<b>30-W-4</b>		Bearing Bars at 1-7/8" O.C. Cross Bars at 4" O.C.	<b>30-W-2</b> 
<b>38-W-4</b>		Bearing Bars at 2-3/8" O.C. Cross Bars at 4" O.C.	<b>38-W-2</b> 



## Heavy Duty Bar Grating Specification Criteria

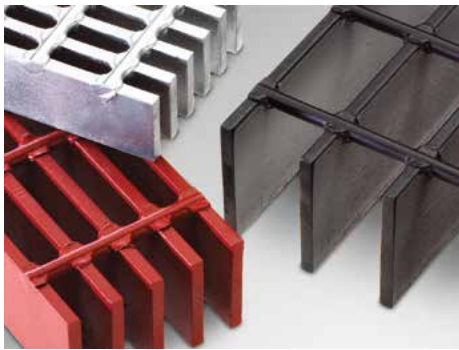

### Bearing Bar Selection

Once the bar spacing is selected, the bearing bar size must be specified based upon the Maximum Traffic Conditions and the unsupported clear span to be served. Consult the load tables for the maximum clear span of our most popular products.

For maximum durability, our load tables incorporate strict limitations where design deflection shall not exceed the lesser of L/400 or .125" for the spans indicated.

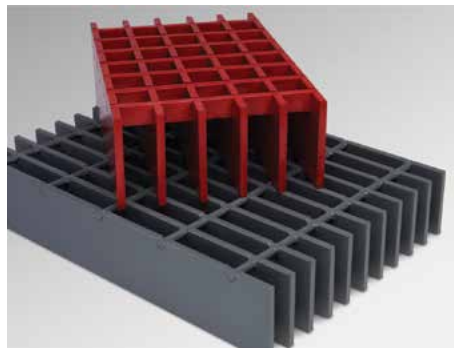

### Cross Bar Selection

While bearing bar selection is critical for specifying a proper heavy duty grating, the life cycle of your installation will often be influenced by the selection of the appropriate cross bar. The table below details the variety of cross bar sizes available.

The cross bars listed for standard loads are the customary twisted square or round cross bars supplied by Grating Pacific for a particular bearing bar size and

spacing. These sizes have been selected to maximize manufacturing efficiency and are best used when the grating is subject to intermittent traffic with occasional full capacity loading.

The cross bars listed for severe loads are optional and will provide superior durability when gratings are subject to intense, continuous, or repetitious traffic. These robust cross bars increase lateral stiffness thereby extending the service life of the grating. When specifying gratings with bearing bars centered at 1-3/8", 1-7/8", or 2-3/8" on center, consideration of Severe Loading cross bars is highly recommended.

**Note: In the event that a cross bar size is not specified, the cross bar shall be selected at the discretion of the manufacturer.**

### How to Specify

1. Select type of grating
  - “W” for welded steel grating
  - “WS” for stainless steel grating
2. Select bar spacing from Table of Spacings
3. Select bearing bar size from Load Tables
4. Specify cross bar size from table
5. Specify plain or serrated surface
6. Specify banding and any additional trim required
7. Specify finish
  - Bare steel (no finish)
  - Painted (red or black)
  - Hot Dip Galvanized (per ASTM A123)
  - Other
8. Specify fasteners (if required) – see Bar Grating Fasteners (page 20)

#### HEAVY DUTY GRATING CROSS BARS

Bearing Bar Size		BB Centers 15/16", 1-3/16", & 1-3/8"		BB Centers 1-7/8" & 2-3/8"	
Thickness	Depth	Standard Loads	Severe Loads	Standard Loads	Severe Loads
1/4"	1" - 2-1/2"	5/16" Twisted	5/16" Twisted	5/16" Twisted	5/16" Twisted
5/16"	1" - 2-1/2"	5/16" Twisted	5/16" Twisted	5/16" Twisted	5/16" Twisted
3/8"	1" - 2-1/2"	5/16" Twisted	5/16" Twisted	5/16" Twisted	5/16" Twisted
1/4"	3" - 5"	5/16" Twisted	1" x 1/4"	3/8" Round	1" x 1/4"
5/16" - 1/2"	3" - 5"	3/8" Round	1" x 3/8"	7/16" Round	1" x 3/8"
1/4"	5-1/2" - 7"	3/8" Round	1-1/4" x 1/4"	7/16" Round	1-1/4" x 1/4"
5/16" - 1/2"	5-1/2" - 7"	3/8" Round	1-1/4" x 3/8"	7/16" Round	1-1/4" x 3/8"

The sizes shown above are listed as minimums. Twisted and round cross bars are typically interchangeable and, unless otherwise specified, may be substituted at the discretion of the manufacturer. In substitution, the cross sectional area of the alternative cross bar shall equal or exceed the minimum size listed above.

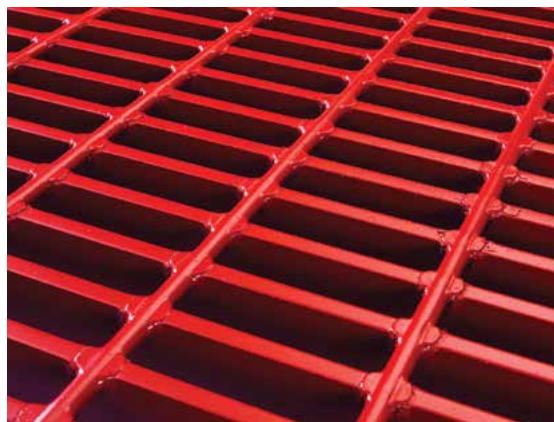

For additional load table information click link: [Heavy Duty Bar Grating](#)

# METAL BAR GRATING

## EMBED FRAMES

Embed frames, cast into concrete floors and substructures, form a rigid shield for concrete leading edges and perimeters that are subject to cracking and chipping when unprotected. During construction, these rigid (1/4" minimum thickness) frames expedite forming and help assure an accurate concrete pour. Upon proper installation, frames serve as a uniform bearing surface for grates or covers to limit rocking or irregular elevations.



### E-Z Pour Frames

Assembled with continuous anchors on the non-bearing sides, E-Z Pour frames install quickly and provide superior drainage.

When specifying, indicate the clear opening dimensions, "W" (width) and "S" (span). Nail holes are optional and must be specified if desired.

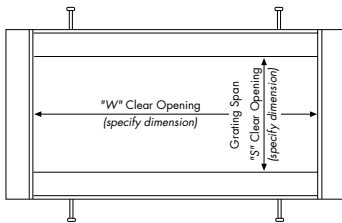

### Welded Frames

All frames are available in four-sided, one-piece, welded construction units that can accommodate any clear opening. Various frame sections (illustrated below) provide assorted options for edge protection.

Specify the desired frame section, clear opening ("W" and "S" dimensions), and desired grating or cover thickness. Nail holes are optional and must be specified if desired.

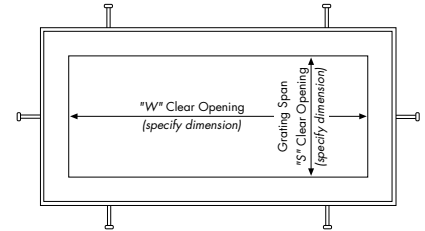

### Frame Sections

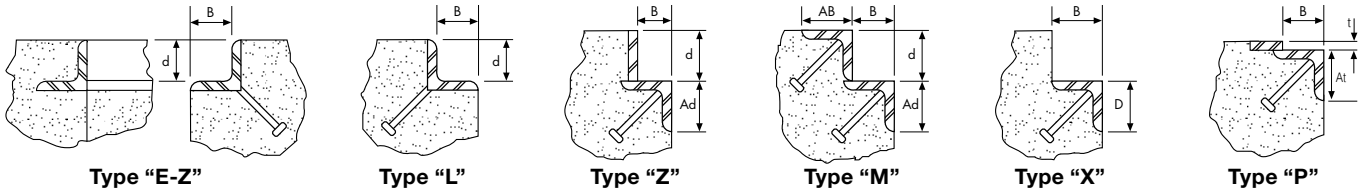

### Anchors

All frames are provided with standard 3/8" x 4" headed concrete stud anchors welded within 6" of each end and at a maximum of 24" on center. Alternative anchor sizes and spacings may be specified.

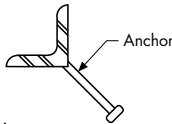

### Materials & Finishes

Carbon steel frames are provided with one of three standard finishes, bare steel (no finish), painted, or hot dip galvanized, after fabrication. Aluminum frames are provided mill finish and can be specified with bituminous coating on surfaces to be cast in concrete. Stainless steel frames are supplied mill finish and can be specified as abrasive blasted after fabrication to provide a uniform matte finish.

EMBED FRAME SIZES & OPTIONS													
Model Number	"d"	"B"	Model Number	"d"	"B"	Model Number	"d"	"B"	"Ad"	Model Number	"d"	"B"	"Ad"
EZ-75	3/4"	3/4"	L-75	3/4"	3/4"	Z-75	3/4"	1"	1-1/2"	M-75	3/4"	1-1/2"	2"
EZ-100	1"	1"	L-100	1"	1"	Z-100	1"	1-1/4"	1-3/4"	M-100	1"	1-1/2"	2"
EZ-125	1-1/4"	1-1/4"	L-125	1-1/4"	1-1/4"	Z-125	1-1/4"	1-1/2"	2"	M-125	1-1/4"	1-1/2"	2"
EZ-150	1-1/2"	1-1/2"	L-150	1-1/2"	1-1/2"	Z-150	1-1/2"	1-1/2"	2"	M-150	1-1/2"	1-1/2"	2"
EZ-175	1-3/4"	1-3/4"	L-175	1-3/4"	1-3/4"	Z-175	1-3/4"	2"	2-1/2"	M-175	1-3/4"	2"	2"
EZ-200	2"	2-1/4"	L-200	2"	2-1/4"	Z-200	2"	2"	2-1/2"	M-200	2"	2"	2"
EZ-225	2-1/4"	2-1/4"	L-225	2-1/4"	2-1/4"	Z-225	2-1/4"	2"	2-1/2"	M-225	2-1/4"	2"	2"
EZ-250	2-1/2"	2-1/4"	L-250	2-1/2"	2-1/4"	Z-250	2-1/2"	2-1/2"	3"	M-250	2-1/2"	2"	2"
EZ-300	3"	2-3/4"	L-300	3"	2-3/4"	Z-300	3"	2-1/2"	3"	M-300	3"	2"	2"
EZ-350	3-1/2"	2-3/4"	L-350	3-1/2"	2-3/4"	Z-350	3-1/2"	2-1/2"	3"	M-350	3-1/2"	3"	2-1/2"
EZ-400	4"	2-3/4"	L-400	4"	2-3/4"	Z-400	4"	3"	3-1/2"	M-400	4"	3"	2-1/2"
EZ-500	5"	3-1/4"	L-500	5"	3-1/4"	Z-500	5"	3"	3-1/2"	M-500	5"	3-1/2"	3"
EZ-600	6"	3-1/4"	L-600	6"	3-1/4"	Z-600	6"	3"	3-1/2"	M-600	6"	3-1/2"	3"
Model Number	"B"	"D"	Model Number	"B"	"D"	Model Number	"B"	"D"		Model Number	"t"	"B"	"At"
X-100	1"	1"	X-400	4"	4"	X-3530	3-1/2"	3"	—	P-125	1/8"	1-1/2"	2"
X-125	1-1/4"	1-1/4"	X-500	5"	5"	X-4030	4"	3"	—	P-188	3/16"	1-1/2"	2"
X-150	1-1/2"	1-1/2"	X-600	6"	6"	X-5030	5"	3"	—	P-250	1/4"	1-1/2"	2"
X-175	1-3/4"	1-3/4"	X-2515	2-1/2"	1-1/2"	X-5035	5"	3-1/2"	—	P-313	5/16"	1-1/2"	2"
X-200	2"	2"	X-2520	2-1/2"	2"	X-6035	6"	3-1/2"	—	P-375	3/8"	1-1/2"	2"
X-250	2-1/2"	2-1/2"	X-3020	3"	2"	X-6040	6"	4"	—	P-500	1/2"	1-1/2"	2"
X-300	3"	3"	X-3025	3"	2-1/2"	—	—	—	—	P-625	5/8"	2"	2-1/2"
X-350	3-1/2"	3-1/2"	X-3525	3-1/2"	2-1/2"	—	—	—	—	P-750	3/4"	2"	2-1/2"
—	—	—	—	—	—	—	—	—	—	P-1000	1"	2"	2-1/2"



## TRENCH & INLET SYSTEMS

Grating Pacific trench and inlet systems combine our most popular gratings and embed frames in a complete set for economic, simple installation on construction projects. Systems are available in standard duty for pedestrian loads and heavy duty for demanding vehicular traffic.



## TYPES OF TRENCH & INLET SYSTEMS

### Standard Duty



#### Type "S"

Designed to support pedestrian loads, type "S" grates are manufactured from welded grating with durable 3/16" (min.) thick bearing bars. Open area of nearly 80% allows for fast clearing of moisture and run off.



#### Type "SA"

Standard duty type "SA" grates are designed to conform with strict ADA spacing requirements. Open area of 68% allows for drainage and ventilation while maintaining a safe traffic surface.



#### Type "SP"

Type "SP" grates comply with ADA spacing requirements. Additionally, the 1/4" maximum clear opening between the bearing bars makes these grates desirable in areas subject to pedestrian traffic where high heel shoes are expected.

### Heavy Duty



#### Type "H"

Type "H" grates are manufactured from stout 3/8" (min.) thick bearing bars and designed to serve truck and forklift loads. With nearly 70% open area, these products are ideal for parking lot and highway drain applications.



#### Type "HA"

Heavy Duty type "HA" grates are ADA conforming, similar to type "SA" above. These grates are additionally designed to support forklift and vehicular loads.



#### Type "HP"

Heavy Duty type "HP" grates are similar to type "SP" above, in that they are ADA conforming, high heel resistant, and also designed to support forklift and vehicular loads.

# METAL BAR GRATING

## Bolting Options

Trench and inlet systems are manufactured as component products with grates easily removed for clearing debris. Security concerns or traffic conditions may dictate that grates be bolted to the framing. When this option is specified, weld lugs or countersunk lands are installed on the grates and the bolt is installed below the traffic surface of the grating.



Bolted Grates with Weld Lugs



Tamper-Resistant Bolt with Weld Lug



Close Mesh Bolting with Countersunk Land

## TRENCH GRATING SYSTEMS

Grating Pacific allows the specifier to combine any of our Standard Duty pedestrian grates or Heavy Duty vehicular gratings with any of our Embed Frames. This flexible system allows the user to specify the exact clear opening ("S" dimension) desired.



Please select a frame (see page 16) to meet the exact edge condition desired. Bolting the grates to the frames is optional and must be specified at time of order.

All gratings are manufactured with a plain walking surface, optional serrated surfaces may be specified. Open ends of all inlet gratings are trench banded to allow for maximum drainage.

Trench frames and grating are hot dip galvanized after fabrication in accordance with ASTM Specification A123. Other finishes may be specified.

## How to Specify Trench Grating Systems

# TH-12-EZ(B)

Indicates trench clear span or "S" dimension.



"T" indicates trench grating, "H" indicates Heavy Duty Grating (type H, HA, or HP). For Standard Duty, indicate type S, SA, or SP.

Indicates type of frame.

Optional component to specify bolted grates. If bolted grates are not required, this suffix is omitted.

### STANDARD TRENCH SYSTEMS

#### Standard Duty

Standard Duty									Heavy Duty   								
Model Number	"S"	"d"	Model Number	"S"	"d"	Model Number	"S"	"d"	Model Number	"S"	"d"	Model Number	"S"	"d"	Model Number	"d"	"d"
TS-6-EZ	6"	1"	TSA-6-EZ	6"	1"	TSP-6-EZ	6"	1"	TH-6-EZ	6"	1-1/2"	THA-6-EZ	6"	1-1/2"	THP-6-EZ	6"	1-1/2"
TS-8-EZ	8"	1"	TSA-8-EZ	8"	1"	TSP-8-EZ	8"	1"	TH-8-EZ	8"	1-1/2"	THA-8-EZ	8"	1-1/2"	THP-8-EZ	8"	1-1/2"
TS-10-EZ	10"	1"	TSA-10-EZ	10"	1"	TSP-10-EZ	10"	1"	TH-10-EZ	10"	1-1/2"	THA-10-EZ	10"	1-1/2"	THP-10-EZ	10"	1-1/2"
TS-12-EZ	12"	1"	TSA-12-EZ	12"	1"	TSP-12-EZ	12"	1"	TH-12-EZ	12"	1-1/2"	THA-12-EZ	12"	1-3/4"	THP-12-EZ	12"	1-1/2"
TS-14-EZ	14"	1"	TSA-14-EZ	14"	1"	TSP-14-EZ	14"	1"	TH-14-EZ	14"	1-3/4"	THA-14-EZ	14"	2-1/4"	THP-14-EZ	14"	1-3/4"
TS-16-EZ	16"	1"	TSA-16-EZ	16"	1"	TSP-16-EZ	16"	1"	TH-16-EZ	16"	2-1/4"	THA-16-EZ	16"	2-1/4"	THP-16-EZ	16"	1-3/4"
TS-18-EZ	18"	1"	TSA-18-EZ	18"	1"	TSP-18-EZ	18"	1"	TH-18-EZ	18"	2-1/4"	THA-18-EZ	18"	2-1/4"	THP-18-EZ	18"	2-1/4"
TS-20-EZ	20"	1"	TSA-20-EZ	20"	1-1/4"	TSP-20-EZ	20"	1"	TH-20-EZ	20"	2-1/4"	THA-20-EZ	20"	2-1/2"	THP-20-EZ	20"	2-1/4"
TS-22-EZ	22"	1"	TSA-22-EZ	22"	1-1/4"	TSP-22-EZ	22"	1"	TH-22-EZ	22"	2-1/4"	THA-22-EZ	22"	2-1/2"	THP-22-EZ	22"	2-1/4"
TS-24-EZ	24"	1"	TSA-24-EZ	24"	1-1/4"	TSP-24-EZ	24"	1"	TH-24-EZ	24"	2-1/4"	THA-24-EZ	24"	2-1/2"	THP-24-EZ	24"	2-1/4"
TS-27-EZ	27"	1"	TSA-27-EZ	27"	1-1/4"	TSP-27-EZ	27"	1"	TH-27-EZ	27"	2-1/2"	THA-27-EZ	27"	2-1/2"	THP-27-EZ	27"	2-1/4"
TS-30-EZ	30"	1"	TSA-30-EZ	30"	1-1/4"	TSP-30-EZ	30"	1"	TH-30-EZ	30"	3"	THA-30-EZ	30"	2-1/2"	THP-30-EZ	30"	2-1/2"
TS-33-EZ	33"	1"	TSA-33-EZ	33"	1-1/2"	TSP-33-EZ	33"	1-1/4"	TH-33-EZ	33"	3"	THA-33-EZ	33"	3"	THP-33-EZ	33"	2-1/2"
TS-36-EZ	36"	1"	TSA-36-EZ	36"	1-1/2"	TSP-36-EZ	36"	1-1/4"	TH-36-EZ	36"	3"	THA-36-EZ	36"	3"	THP-36-EZ	36"	2-1/2"
TS-42-EZ	42"	1"	TSA-42-EZ	42"	1-1/2"	TSP-42-EZ	42"	1-1/4"	TH-42-EZ	42"	3-1/2"	THA-42-EZ	42"	3"	THP-42-EZ	42"	3"
TS-48-EZ	48"	1-1/4"	TSA-48-EZ	48"	1-3/4"	TSP-48-EZ	48"	1-1/2"	TH-48-EZ	48"	3-1/2"	THA-48-EZ	48"	3-1/2"	THP-48-EZ	48"	3"
TS-54-EZ	54"	1-1/2"	TSA-54-EZ	54"	1-3/4"	TSP-54-EZ	54"	1-1/2"	TH-54-EZ	54"	4"	THA-54-EZ	54"	3-1/2"	THP-54-EZ	54"	3"
TS-60-EZ	60"	1-3/4"	TSA-60-EZ	60"	2-1/4"	TSP-60-EZ	60"	1-1/2"	TH-60-EZ	60"	4"	THA-60-EZ	60"	4"	THP-60-EZ	60"	3-1/2"
TS-66-EZ	66"	1-3/4"	TSA-66-EZ	66"	2-1/4"	TSP-66-EZ	66"	1-1/2"	TH-66-EZ	66"	5"	THA-66-EZ	66"	4"	THP-66-EZ	66"	3-1/2"
TS-72-EZ	72"	2"	TSA-72-EZ	72"	2-1/4"	TSP-72-EZ	72"	1-3/4"	TH-72-EZ	72"	5"	THA-72-EZ	72"	4"	THP-72-EZ	72"	4"



## INLET GRATES & FRAMES

Grating Pacific inlet grates and frames provide flexible solutions to inlet drain requirements. Standard Duty pedestrian grates and Heavy Duty vehicular grates may be specified to any clear opening by indicating the desired "W" (width) and "S" (span) dimensions (see page 16). Any of our five Embed Frame profiles may be specified. Bolting the grates to the frames is optional and must be specified at time of order.

All gratings are manufactured with a plain walking surface. Optional serrated surfaces may be specified. Open ends of all inlet gratings are trench banded to allow for maximum drainage.

All inlet grates and frames are hot dip galvanized in accordance with ASTM specification A123. Other finishes may be specified.

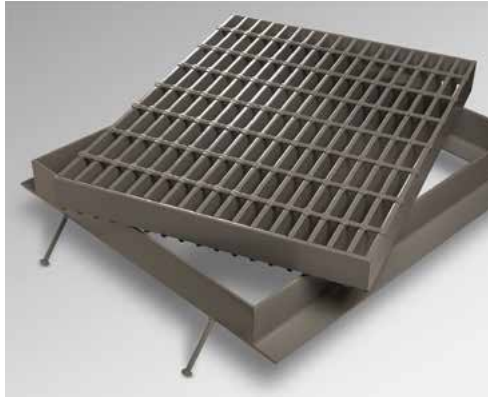

### How to Specify Inlet Grates & Frames

## H-3624-EZ(B)

Indicates frame "W" clear opening in inches.

Indicates frame "S" clear opening in inches.

Indicates type of frame.

Specify Heavy Duty Grating (type H, HA, or HP), or Standard Duty, (indicate type S, SA, or SP).

Optional component to specify bolted grates. If bolted grates are not required, this suffix is omitted.

## Standard Inlet Sets

Standard inlet sets listed below consist of our "E-Z Pour" frames with either of two popular series of grating. Standard Duty type "S" grates are selected for pedestrian applications and type "H" Heavy Duty grates are selected for vehicular load applications.

STANDARD DUTY SQUARE INLET SETS							
Model Number	"W"	"S"	"d"	Model Number	"W"	"S"	"d"
S-0606-EZ	6"	6"	1"	S-3333-EZ	33"	33"	1"
S-0808-EZ	8"	8"	1"	S-3636-EZ	36"	36"	1"
S-1010-EZ	10"	10"	1"	S-4242-EZ	42"	42"	1"
S-1212-EZ	12"	12"	1"	S-4848-EZ	48"	48"	1-1/4"
S-1414-EZ	14"	14"	1"	S-5454-EZ	54"	54"	1-1/2"
S-1616-EZ	16"	16"	1"	S-6060-EZ	60"	60"	1-3/4"
S-1818-EZ	18"	18"	1"	S-6666-EZ	66"	66"	1-3/4"
S-2020-EZ	20"	20"	1"	S-7272-EZ	72"	72"	2"
S-2222-EZ	22"	22"	1"	S-7878-EZ	78"	78"	2-1/4"
S-2424-EZ	24"	24"	1"	S-8484-EZ	84"	84"	2-1/2"
S-2727-EZ	27"	27"	1"	S-9696-EZ	96"	96"	2-1/2"
S-3030-EZ	30"	30"	1"				

HEAVY DUTY SQUARE INLET SETS							
Model Number	"W"	"S"	"d"	Model Number	"W"	"S"	"d"
H-0606-EZ	6"	6"	1-1/2"	H-3333-EZ	33"	33"	3"
H-0808-EZ	8"	8"	1-1/2"	H-3636-EZ	36"	36"	3"
H-1010-EZ	10"	10"	1-1/2"	H-4242-EZ	42"	42"	3-1/2"
H-1212-EZ	12"	12"	1-1/2"	H-4848-EZ	48"	48"	3-1/2"
H-1414-EZ	14"	14"	1-3/4"	H-5454-EZ	54"	54"	4"
H-1616-EZ	16"	16"	2-1/4"	H-6060-EZ	60"	60"	4"
H-1818-EZ	18"	18"	2-1/4"	H-6666-EZ	66"	66"	5"
H-2020-EZ	20"	20"	2-1/4"	H-7272-EZ	72"	72"	5"
H-2222-EZ	22"	22"	2-1/4"	H-7878-EZ	78"	78"	5"
H-2424-EZ	24"	24"	2-1/4"	H-8484-EZ	84"	84"	6"
H-2727-EZ	27"	27"	2-1/2"	H-9696-EZ	96"	96"	6"
H-3030-EZ	30"	30"	3"				

STANDARD DUTY RECTANGULAR INLET SETS							
Model Number	"W"	"S"	"d"	Model Number	"W"	"S"	"d"
S-1206-EZ	12"	6"	1"	S-0612-EZ	6"	12"	1"
S-1210-EZ	12"	10"	1"	S-0618-EZ	6"	18"	1"
S-1806-EZ	18"	6"	1"	S-0624-EZ	6"	24"	1"
S-1812-EZ	18"	12"	1"	S-0630-EZ	6"	30"	1"
S-2406-EZ	24"	6"	1"	S-0636-EZ	6"	36"	1"
S-2412-EZ	24"	12"	1"	S-1218-EZ	12"	18"	1"
S-2418-EZ	24"	18"	1"	S-1224-EZ	12"	24"	1"
S-3006-EZ	30"	6"	1"	S-1230-EZ	12"	30"	1"
S-3012-EZ	30"	12"	1"	S-1236-EZ	12"	36"	1"
S-3018-EZ	30"	18"	1"	S-1248-EZ	12"	48"	1-1/4"
S-3024-EZ	30"	24"	1"	S-1824-EZ	18"	24"	1"
S-3606-EZ	36"	6"	1"	S-1830-EZ	18"	30"	1"
S-3612-EZ	36"	12"	1"	S-1836-EZ	18"	36"	1"
S-3618-EZ	36"	18"	1"	S-1842-EZ	18"	42"	1"
S-3624-EZ	36"	24"	1"	S-1848-EZ	18"	48"	1-1/4"
S-3630-EZ	36"	30"	1"	S-2430-EZ	24"	30"	1"
S-4812-EZ	48"	12"	1"	S-2436-EZ	24"	36"	1"
S-4818-EZ	48"	18"	1"	S-2442-EZ	24"	42"	1"
S-4824-EZ	48"	24"	1"	S-2448-EZ	24"	48"	1-1/4"
S-4836-EZ	48"	36"	1"	S-2454-EZ	24"	54"	1-1/2"

HEAVY DUTY RECTANGULAR INLET SETS							
Model Number	"W"	"S"	"d"	Model Number	"W"	"S"	"d"
H-1206-EZ	12"	6"	1-1/2"	H-0612-EZ	6"	12"	1-1/2"
H-1210-EZ	12"	10"	1-1/2"	H-0618-EZ	6"	18"	2-1/4"
H-1806-EZ	18"	6"	1-1/2"	H-0624-EZ	6"	24"	2-1/4"
H-1812-EZ	18"	12"	1-1/2"	H-0630-EZ	6"	30"	3"
H-2406-EZ	24"	6"	1-1/2"	H-0636-EZ	6"	36"	3"
H-2412-EZ	24"	12"	1-1/2"	H-1218-EZ	12"	18"	2-1/4"
H-2418-EZ	24"	18"	2-1/4"	H-1224-EZ	12"	24"	2-1/4"
H-3006-EZ	30"	6"	1-1/2"	H-1230-EZ	12"	30"	3"
H-3012-EZ	30"	12"	1-1/2"	H-1236-EZ	12"	36"	3"
H-3018-EZ	30"	18"	2-1/4"	H-1248-EZ	12"	48"	3-1/2"
H-3024-EZ	30"	24"	2-1/4"	H-1824-EZ	18"	24"	2-1/4"
H-3606-EZ	36"	6"	1-1/2"	H-1830-EZ	18"	30"	3"
H-3612-EZ	36"	12"	1-1/2"	H-1836-EZ	18"	36"	3"
H-3618-EZ	36"	18"	2-1/4"	H-1842-EZ	18"	42"	3-1/2"
H-3624-EZ	36"	24"	2-1/4"	H-1848-EZ	18"	48"	3-1/2"
H-3630-EZ	36"	30"	3"	H-2430-EZ	24"	30"	3"
H-4812-EZ	48"	12"	1-1/2"	H-2436-EZ	24"	36"	3"
H-4818-EZ	48"	18"	2-1/4"	H-2442-EZ	24"	42"	3-1/2"
H-4824-EZ	48"	24"	2-1/4"	H-2448-EZ	24"	48"	3-1/2"
H-4836-EZ	48"	36"	3"	H-2454-EZ	24"	54"	4"

# METAL BAR GRATING

STANDARD DUTY RECTANGULAR INLET SETS							
Model Number	"W"	"S"	"d"	Model Number	"W"	"S"	"d"
S-6012-EZ	60"	12"	1"	S-2460-EZ	24"	60"	1-3/4"
S-6018-EZ	60"	18"	1"	S-3036-EZ	30"	36"	1"
S-6024-EZ	60"	24"	1"	S-3042-EZ	30"	42"	1"
S-6036-EZ	60"	36"	1"	S-3048-EZ	30"	48"	1-1/4"
S-6048-EZ	60"	48"	1-1/4"	S-3054-EZ	30"	54"	1-1/2"
S-7212-EZ	72"	12"	1"	S-3060-EZ	30"	60"	1-3/4"
S-7218-EZ	72"	18"	1"	S-3072-EZ	30"	72"	2"
S-7224-EZ	72"	24"	1"	S-3642-EZ	36"	42"	1"
S-7236-EZ	72"	36"	1"	S-3648-EZ	36"	48"	1-1/4"
S-7248-EZ	72"	48"	1-1/4"	S-3654-EZ	36"	54"	1-1/2"
S-8412-EZ	84"	12"	1"	S-3660-EZ	36"	60"	1-3/4"
S-8424-EZ	84"	24"	1"	S-4248-EZ	42"	48"	1-1/4"
S-8436-EZ	84"	36"	1"	S-4254-EZ	42"	54"	1-1/2"
S-8448-EZ	84"	48"	1-1/4"	S-4260-EZ	42"	60"	1-3/4"
S-9612-EZ	96"	12"	1"	S-4854-EZ	48"	54"	1-1/2"
S-9624-EZ	96"	24"	1"	S-4860-EZ	48"	60"	1-3/4"
S-9636-EZ	96"	36"	1"	S-4872-EZ	48"	72"	2"
S-9648-EZ	96"	48"	1-1/4"	S-6072-EZ	60"	72"	2"
S-9672-EZ	96"	72"	2"				

HEAVY DUTY RECTANGULAR INLET SETS							
Model Number	"W"	"S"	"d"	Model Number	"W"	"S"	"d"
H-6012-EZ	60"	12"	1-1/2"	H-2460-EZ	24"	60"	4"
H-6018-EZ	60"	18"	2-1/4"	H-3036-EZ	30"	36"	3"
H-6024-EZ	60"	24"	2-1/4"	H-3042-EZ	30"	42"	3-1/2"
H-6036-EZ	60"	36"	3"	H-3048-EZ	30"	48"	3-1/2"
H-6048-EZ	60"	48"	3-1/2"	H-3054-EZ	30"	54"	4"
H-7212-EZ	72"	12"	1-1/2"	H-3060-EZ	30"	60"	4"
H-7218-EZ	72"	18"	2-1/4"	H-3072-EZ	30"	72"	5"
H-7224-EZ	72"	24"	2-1/4"	H-3642-EZ	36"	42"	3-1/2"
H-7236-EZ	72"	36"	3"	H-3648-EZ	36"	48"	3-1/2"
H-7248-EZ	72"	48"	3-1/2"	H-3654-EZ	36"	54"	4"
H-8412-EZ	84"	12"	1-1/2"	H-3660-EZ	36"	60"	4"
H-8424-EZ	84"	24"	2-1/4"	H-4248-EZ	42"	48"	3-1/2"
H-8436-EZ	84"	36"	3"	H-4254-EZ	42"	54"	4"
H-8448-EZ	84"	48"	3-1/2"	H-4260-EZ	42"	60"	4"
H-9612-EZ	96"	12"	1-1/2"	H-4854-EZ	48"	54"	4"
H-9624-EZ	96"	24"	2-1/4"	H-4860-EZ	48"	60"	4"
H-9636-EZ	96"	36"	3"	H-4872-EZ	48"	72"	5"
H-9648-EZ	96"	48"	3-1/2"	H-6072-EZ	60"	72"	5"
H-9672-EZ	96"	72"	5"				

Any of the above Inlet Sets can be customized to meet the specific needs of your construction project. To select Standard Duty ADA conforming or close mesh gratings, simply substitute "SA" or "SP" in lieu of the "S" component in the model number. Heavy Duty models can be similarly modified by inserting "HA" or "HP." To select alternative frame construction, select the frame type from page 16 and replace component "EZ" in the model number. Bolted grates must be specified by adding the "(B)" suffix to the model number.

## WELDED INSTALLATION AND FASTENERS

Welding will provide a superior, permanent installation. Mechanical fasteners are available when the grating needs to be removable or welding is not practical.

The recommended minimum weld pattern also indicates the minimum fastener spacing for pedestrian applications.

Vehicular applications typically require additional welding, size, and spacing determined by the specifying authority.

One weld in middle of panel at each intermediate support

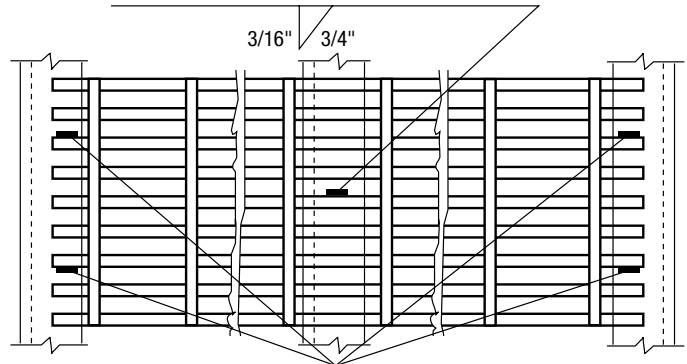

Welds at ends of bearing bar approximately 6" from each side of panel

## Bar Grating Fasteners



Saddle Clips

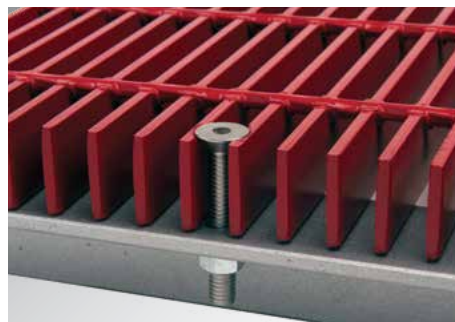

Countersunk Lands



Weld Lugs



"G" Clips



"E-11" Clips



"J" Clips



## BAR GRATING FABRICATION

### Engineering

Grating Pacific offers complete engineering services from concept to production. Available services include:

- Design consultation
- Technical manuals
- Field technical representatives
- CAD drafting
- Engineering certification
- Custom design services



### Customization

Our fully trained production staff will transform stock panels into custom components to your exact specification. We will layout and cut our products to any configuration. We also fabricate stair treads, frames, and install lifting devices on products as needed. Shop fabrication eliminates the need for costly field labor and scrap disposal at the project site.

Post-fabrication, all materials can be properly finished to assure maximum life. Additionally, all panels are piece marked to matching installation drawings which accompany product shipment. Our fabrication services are accurate, prompt, and lead to straightforward installation.



### Fabrication Services

We proudly offer in-house fabrication of metal bar grating including:

- Sawing
- Flame and plasma cutting
- Welding
- Punching
- Banding
- Finishing

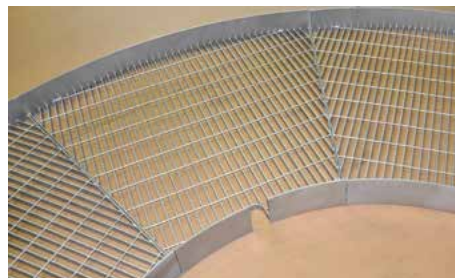
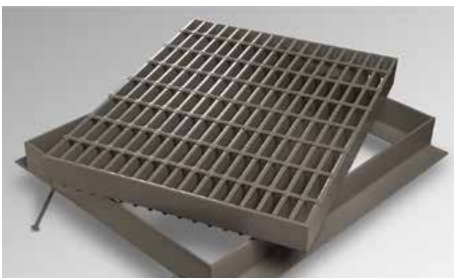
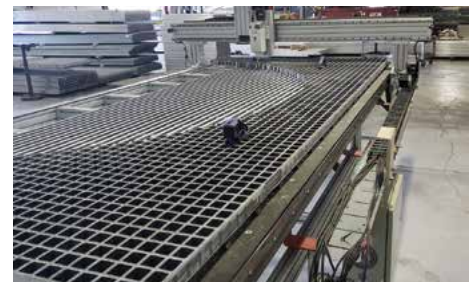





# CODA ARCHITECTURAL PRODUCTS





## CODA Architectural Products



Opus



Aria



Opus50



Opus60 fencing infill with Aria 80LG sunshade (above)



Opus10 Stair Infill Panels

## Architectural Grating Products



Architectural Bar Grating



Louver Grates



## OPUS

Opus grille and louver panels are popular for fencing and screening applications of all types. Stair infill panels range from open, code compliant spacings to closer mesh security products. Louvered panels are commonly preferred for ventilation applications that restrict visual access.

For additional Opus information click link: [Coda Architectural](#)



### Opus10

The most widely used rectangular design, Opus10 features timeless lines combined with unmatched versatility.

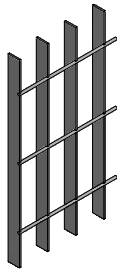

### Opus20

Our most popular square mesh pattern, Opus20 subtly suggests strength, rigidity, and security.

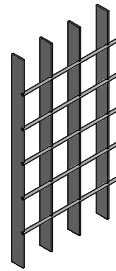

### Opus30

The closely spaced main elements of this design make Opus30 the perfect choice where increased visual blocking is preferred.

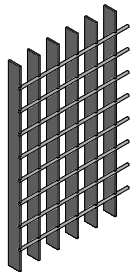
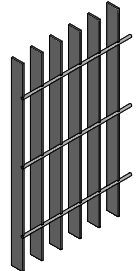

### Opus40

A closely spaced, nominally square pattern, Opus40 has increased rigidity that provides strength and security.

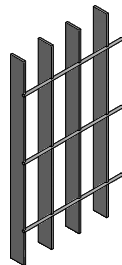

### Opus50

Designed with increased depth and strength, Opus50 has deeper bar sections while maintaining the popular pattern of Opus10.

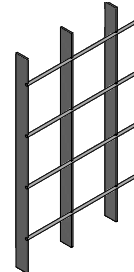

### Opus60

The timeless square pattern of Opus60 complies with IBC spacing requirements for infill panels of all types. (Limited availability)

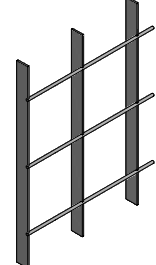

### Opus70

The extra wide spacing of the Opus70 elements minimizes visual impact while providing a permanent physical barrier. (Limited availability)

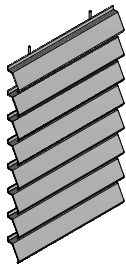

### Opus80

Louvered main elements make Opus80 the ideal panel for applications that require ventilation and minimal visual access.

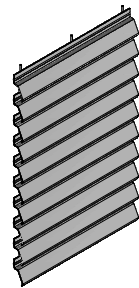

### Opus100

The closer spacing of the louvered main elements in Opus100 increases visual blocking while providing free air flow.

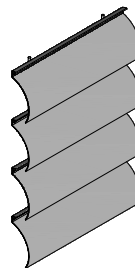

### Opus110S

Solid, radial main elements of Opus110S provide a subtle but distinct variation from traditional steel louvers. (Limited availability)

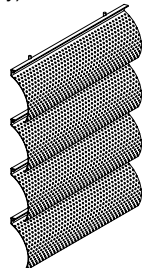

### Opus110P

Curved, perforated main elements offer an alluring alternative to traditional louvered products. (Limited availability)



## ARIA

Lightweight, corrosion resistant aluminum grilles and louvers, Aria products are ideal for sunshades, screening, and specialty infill requirements. Easily fabricated to complement adjacent architecture, Aria products are commonly specified with an anodized finish or powder coated with any RAL color. These finishes assure long-term service with minimal maintenance.



For additional product and specifications click link:  
[Coda Architectural](http://www.codaarchitectural.com)

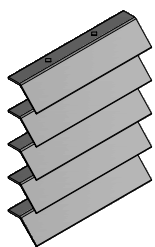

### Aria60LG

Offering 60% visual block at eye level, Aria60LG allows for security while maintaining significant free air flow.

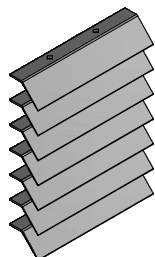

### Aria80LG

The more closely spaced main elements of Aria80LG provide visual blocking of 80% while still allowing ventilation.

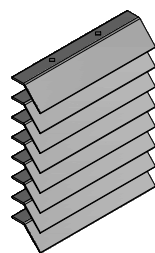

### Aria100LG

Complete visual concealment is achieved through closer spacing of the louver bars on Aria100LG.

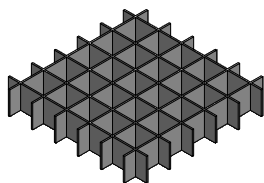

### Aria222

2" deep bars spaced in a 2" x 2" pattern. A timeless combination, easily adapted to a variety of sunshades.

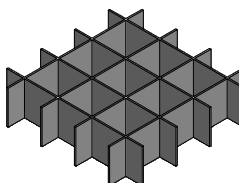

### Aria333

3" deep bars spaced in a 3" x 3" pattern. Maintains proper shade characteristics with a slightly bolder aesthetic.

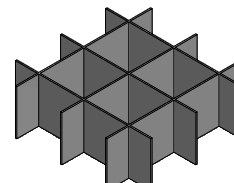

### Aria444

4" deep bars spaced in a 4" x 4" pattern. Recommended where proportionality to larger complementary structural components is required.

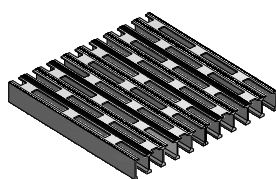

### Aria510

Rectangular holes in a staggered pattern create a unique shading experience with excellent shading characteristics in Aria510.

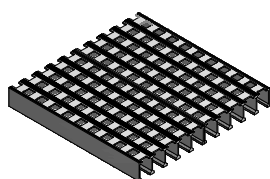

### Aria520

Aria520 extruded aluminum grille-work incorporates a square hole pattern to provide a high level of shading below the panel.

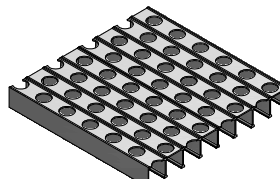

### Aria530

The staggered, round hole pattern of Aria 530 creates a feeling of openness while providing good shading.

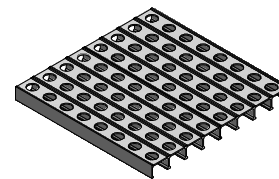

### Aria540

Round holes set in a rectilinear pattern give Aria540 a classic appearance while providing shade to the area below.

## ARCHITECTURAL BAR GRATING

Grating Pacific's complete line of bar gratings and architectural products offers a distinct, contemporary design that is easily incorporated as an architectural accent. Increased spacing between the bearing bars provides security and structural integrity without restricting sight lines and ventilation. The perfect merger of form and function, these products can be fully fabricated to complement design creativity.

- Security
- Ventilation
- Fencing
- Handrail infill
- Sunscreens
- Architectural accents

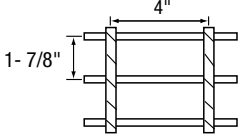
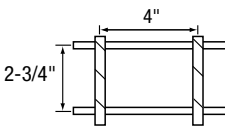
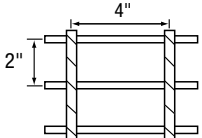
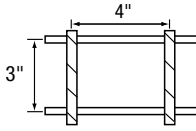
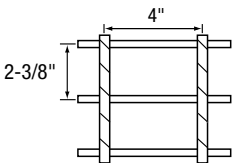
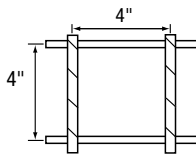

### Architectural Products

ARCHITECTURAL PATTERNS					
<b>30-x-4</b>		Bearing Bars @ 1-7/8" O.C. Cross Bars @ 4" O.C.	<b>44-x-4</b>		Bearing Bars @ 2-3/4" O.C. Cross Bars @ 4" O.C.
<b>32-x-4</b>		Bearing Bars @ 2" O.C. Cross Bars @ 4" O.C.	<b>48-x-4</b>		Bearing Bars @ 3" O.C. Cross Bars @ 4" O.C.
<b>38-x-4</b>		Bearing Bars @ 2-3/8" O.C. Cross Bars @ 4" O.C.	<b>64-x-4</b>		Bearing Bars @ 4" O.C. Cross Bars @ 4" O.C.

Each product is available in steel, aluminum, or stainless steel, assembled by any of the manufacturing methods presented below. To specify the appropriate material and manufacturing method, replace the "x" in the above part number with any of the following designations:

FOR STEEL PRODUCTS	FOR ALUMINUM PRODUCTS	FOR STAINLESS STEEL PRODUCTS
"W" for Welded Grating	"SG" for Swage Locked	"WS" for Welded Grating
"DT" for Dovetail Pressure Locked	"ADT" for Dovetail Pressure Locked	"DTS" for Dovetail Pressure Locked
"SL" for Swage Locked	"SGI" for Swaged I-Bar	"SLS" for Swage Locked
	"SGF" for Swaged Flush Top	

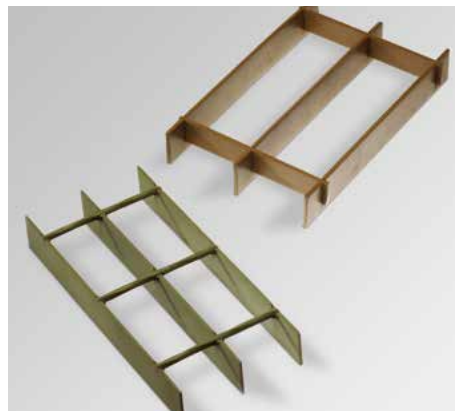

## ALUMINUM LOUVER GRATES

Popular for sunscreens, visual barriers, security systems, grates, and fencing, louver grates may be installed horizontally or vertically depending on the application and intended function. LG series Louver Grates are manufactured from aluminum extrusions and are designed to offer an economical solution for architectural applications. They are available in four popular patterns with total or partial visual concealment. All LG series products offer a minimum 63% open area.



### Louver Grate Spacings

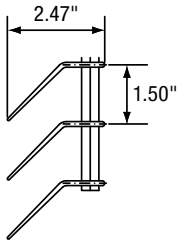

**LG-100 VisiBlock**  
Open Area 63%  
Visual Block 100%

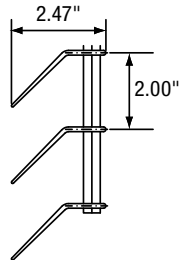

**LG-75 VisiShield**  
Open Area 64%  
Visual Block 77%

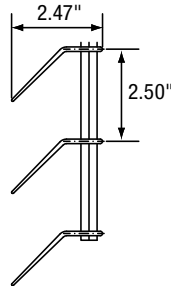

**LG-60 VisiScreen**  
Open Area 64%  
Visual Block 60%

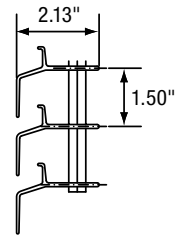

**ZG-100 StormGuard**  
Rain Resistant  
Visual Block 100%

### Finishes

The natural corrosion resistance and beauty of mill finish aluminum can be enhanced with clear anodizing. Other popular anodizing options include light and dark bronze shades.

For an alternative appearance, powder coating, epoxy, and Kynar finishes are available in the complete RAL color palette. Properly applied, these finishes offer years of continuing service in colors designed to complement the look and feel of adjacent architecture.

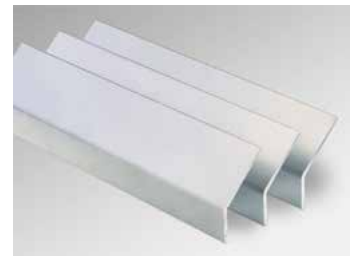





# SAFETY GRATING

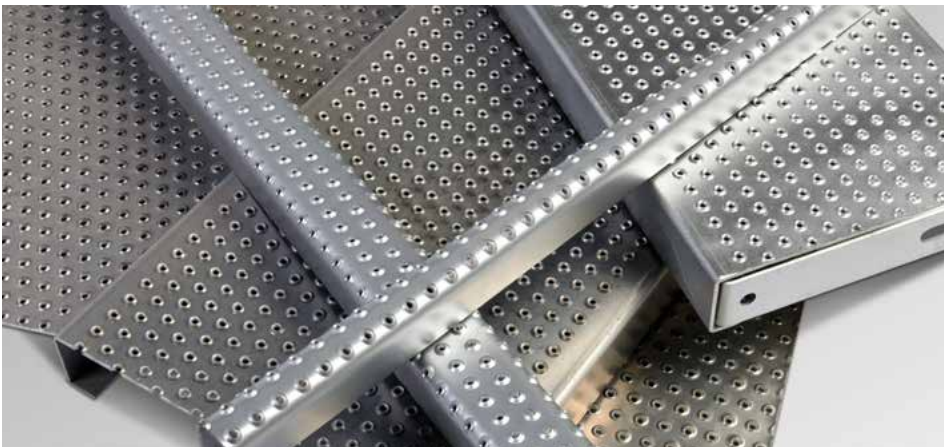



## SAFETY GRATING

Safety Grating is manufactured by cold stamping and forming carbon steel, aluminum, or stainless steel sheet into a one piece, modular plank, or flat sheet, with distinct walking surfaces. Benefits of safety grating include:

- Lightweight material
- Economical
- Easy to fabricate
- Slip-resistant surfaces
- Extremely low maintenance

### Safety Grating Products



Grip Strut®



Perf-O Grip®

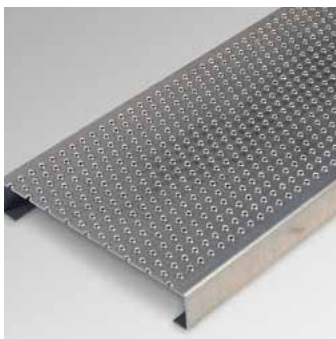

Traction Tread™



Grate-Lock™ Interlocking



Heavy Duty Grip Strut®

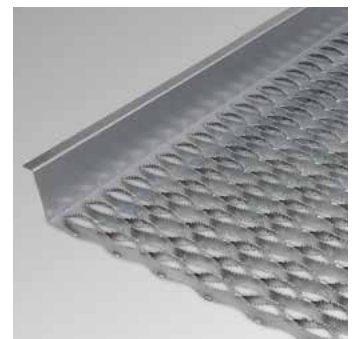

Safety Grating  
Walkway Channels



Safety Grating  
Stair Treads

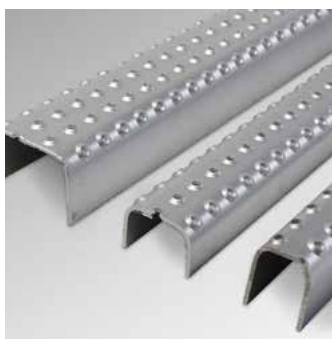

Safety Grating  
Ladder Rungs



Floor Resurfacing Products



## GRIP STRUT® SAFETY GRATING

Grip Strut is the industry leader in safety grating. A versatile, one-piece metal plank, Grip Strut is manufactured with unique diamond shaped openings and formed side channels. Maximum, multi-directional slip resistance is provided by a heavily serrated, diamond matrix walking surface that enhances workplace safety. With approximately 35% open area, fluids easily pass through the grating. Non-serrated surfaces are available upon special request.

### Widths & Depths

Grip Strut planks are available in a broad range of widths and depths for various applications and load requirements.

Standard widths include:

- 2 Diamond (4-3/4" wide)
- 3 Diamond (7" wide)
- 4 Diamond (9-1/2" wide)
- 5 Diamond (11-3/4" wide)
- 8 Diamond (18-3/4" wide)
- 10 Diamond (24" wide)

Standard channel depths include 1-1/2", 2", 2-1/2", and 3".

Stock lengths of 10' and 12' are readily available and custom lengths are available on special order.



### Materials

Grip Strut planks are available in the following materials:

- Pre-galvanized steel, ASTM A924 G90, 14 or 12 gauge
- HRPO uncoated steel, ASTM A1011, 14 or 12 gauge
- 5052-H32 aluminum, ASTM B209, 12 gauge (.080") or 10 gauge (.100")
- 304 or 316L stainless steel, 16 gauge

## GRIP STRUT® FASTENERS

### Grip Strut Diamond Washer

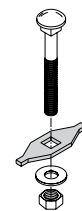
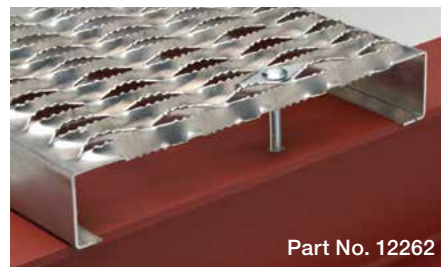

### How to Order Grip Strut

**INDICATES PLANK WIDTH IN NUMBER OF DIAMONDS**  
2, 3, 4, 5, 8, OR 10

**INDICATES CHANNEL DEPTH**  
15 1-1/2"  
20 2"  
25 2-1/2"  
30 3"

**52012**

**INDICATES MATERIAL GAUGE**  
14 or 12 steel,  
12 or 10 aluminum, or  
16 gauge stainless steel

**INDICATES TYPE OF MATERIAL**  
BLANK for pre-galvanized steel  
"B" for HRPO steel  
"A" for aluminum  
"S" for stainless steel

**OTHER EXAMPLES:**

- 31514-B = 7" Wide, 1-1/2" Deep, 14 Gauge HRPO Steel
- 52012-A = 11-3/4" Wide, 2" Deep, .080 Thick Aluminum
- 42016-S = 9-1/2" Wide, 2" Deep, 16 Gauge Stainless Steel

### Anchor Clamp Assembly

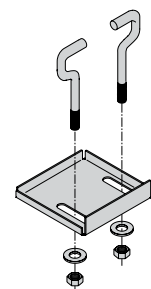

For additional load table information click link:  
[Grip Strut Safety Grating](#)

# GRIP STRUT® SAFETY GRATING

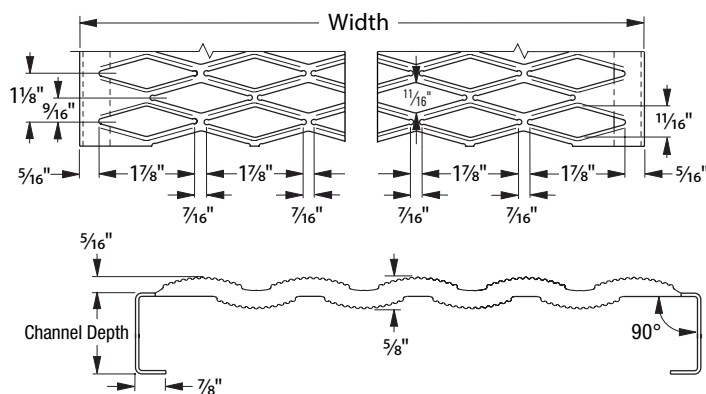

## 2-DIAMOND PLANK 4-3/4" WIDE

Part No.	Width	Channel Depth	Gauge	Weight per LF
<b>14 Ga. Pre-Galvanized Steel*</b>				
21514	4-3/4"	1-1/2"	14	2.3
22014	4-3/4"	2"	14	2.6
22514	4-3/4"	2-1/2"	14	2.8
<b>12 Ga. Pre-Galvanized Steel*</b>				
21512	4-3/4"	1-1/2"	12	3.2
22012	4-3/4"	2"	12	3.6
22512	4-3/4"	2-1/2"	12	4.0
<b>5052 Aluminum</b>				
22012-A	4-3/4"	2"	.080"	0.92
22010-A	4-3/4"	2"	.100"	1.20

## 3-DIAMOND PLANK 7" WIDE

Part No.	Width	Channel Depth	Gauge	Weight per LF
<b>14 Ga. Pre-Galvanized Steel*</b>				
31514	7"	1-1/2"	14	3.0
32014	7"	2"	14	3.2
32514	7"	2-1/2"	14	3.5
<b>12 Ga. Pre-Galvanized Steel*</b>				
31512	7"	1-1/2"	12	4.1
32012	7"	2"	12	4.5
32512	7"	2-1/2"	12	4.9
33012	7"	3"	12	5.2
<b>5052 Aluminum</b>				
32012-A	7"	2"	.080"	1.15
32010-A	7"	2"	.100"	1.46

## 4-DIAMOND PLANK 9-1/2" WIDE

Part No.	Width	Channel Depth	Gauge	Weight per LF
<b>14 Ga. Pre-Galvanized Steel*</b>				
41514	9-1/2"	1-1/2"	14	3.6
42014	9-1/2"	2"	14	3.8
42514	9-1/2"	2-1/2"	14	4.1
<b>12 Ga. Pre-Galvanized Steel*</b>				
41512	9-1/2"	1-1/2"	12	5.0
42012	9-1/2"	2"	12	5.4
42512	9-1/2"	2-1/2"	12	5.7
43012	9-1/2"	3"	12	6.1
<b>5052 Aluminum</b>				
42012-A	9-1/2"	2"	.080"	1.37
42010-A	9-1/2"	2"	.100"	1.74
<b>16 Ga. 304 Stainless Steel</b>				
42016-S	9-1/2"	2"	16	3.2

## 5-DIAMOND PLANK 11-3/4" WIDE

Part No.	Width	Channel Depth	Gauge	Weight per LF
<b>14 Ga. Pre-Galvanized Steel*</b>				
51514	11-3/4"	1-1/2"	14	4.2
52014	11-3/4"	2"	14	4.4
52514	11-3/4"	2-1/2"	14	4.7
<b>12 Ga. Pre-Galvanized Steel*</b>				
51512	11-3/4"	1-1/2"	12	5.9
52012	11-3/4"	2"	12	6.2
52512	11-3/4"	2-1/2"	12	6.6
53012	11-3/4"	3"	12	7.0
<b>5052 Aluminum</b>				
52012-A	11-3/4"	2"	.080"	1.59
52010-A	11-3/4"	2"	.100"	2.00
<b>16 Ga. 304 Stainless Steel</b>				
52016-S	11-3/4"	2"	16	3.7

## 8-DIAMOND PLANK 18-3/4" WIDE

Part No.	Width	Channel Depth	Gauge	Weight per LF
<b>14 Ga. Pre-Galvanized Steel*</b>				
81514	18-3/4"	1-1/2"	14	6.1
82014	18-3/4"	2"	14	6.3
82514	18-3/4"	2-1/2"	14	6.6
<b>12 Ga. Pre-Galvanized Steel*</b>				
81512	18-3/4"	1-1/2"	12	8.5
82012	18-3/4"	2"	12	8.9
82512	18-3/4"	2-1/2"	12	9.2
83012	18-3/4"	3"	12	9.6
<b>5052 Aluminum</b>				
82010-A	18-3/4"	2"	.080"	2.31

## 10-DIAMOND PLANK 24" WIDE

Part No.	Width	Channel Depth	Gauge	Weight per LF
<b>14 Ga. Pre-Galvanized Steel*</b>				
102014	24"	2"	14	7.4
103014	24"	3"	14	7.9
<b>12 Ga. Pre-Galvanized Steel*</b>				
102012	24"	2"	12	10.4
103012	24"	3"	12	11.1

\* To indicate HRPO carbon steel, add the suffix "-B" to the above stated steel part numbers.

Stock plank lengths available in 10' and 12'. Custom lengths available upon special order.

For additional load table information click link:

[Grip Strut Safety Grating](#)



## HEAVY DUTY GRIP STRUT® SAFETY GRATING

Heavy Duty Grip Strut is manufactured with a heavier gauge metal and a larger, serrated, diamond matrix opening when compared to standard Grip Strut. This design supports greater loads on longer spans while providing maximum slip resistance and allowing the passage of mud, snow, ice, or liquids.

### Widths & Depths

Heavy Duty Grip Strut planks are available in a range of widths and depths for demanding applications and loads. Stock lengths of 10' and 12' are readily available with custom lengths available on special order.

Available plank widths include:

- 2 Diamond (9-1/4" wide)
- 3 Diamond (13-3/4" wide)
- 5 Diamond (23-1/4" wide)
- 6 Diamond (27-3/4" wide)
- 8 Diamond (36" wide)

Channel depths offered are 2", 2-1/2", 3" and 4".

### Materials

Heavy Duty Grip Strut planks are available in the following materials:

- 10 gauge, ASTM A924-G90, pre-galvanized steel
- 10 gauge, ASTM A1011, HRPO steel

### Heavy Duty Grip Strut Hold-Down Clip



Part no. H-BC-10

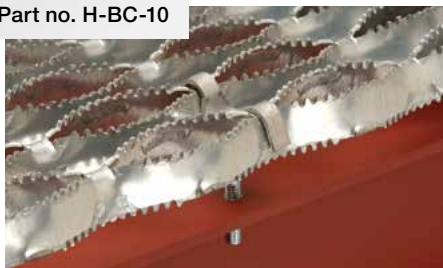

### How to Order Heavy Duty Grip Strut

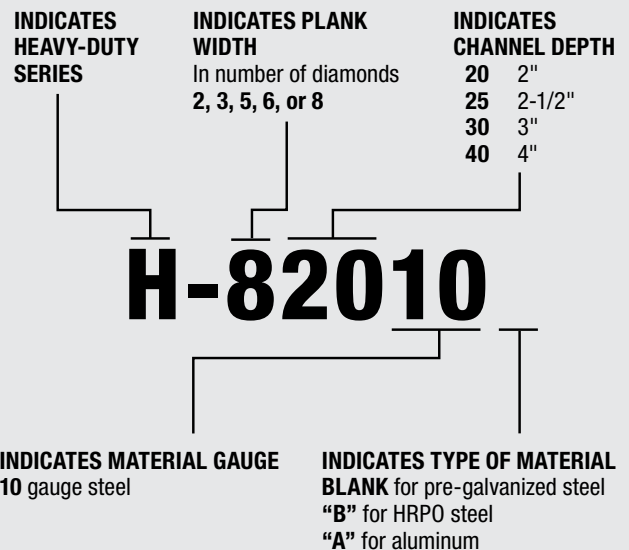

For additional load table information click link:  
[Heavy Duty Grip Strut Safety Grating](#)

# HEAVY DUTY GRIP STRUT® SAFETY GRATING

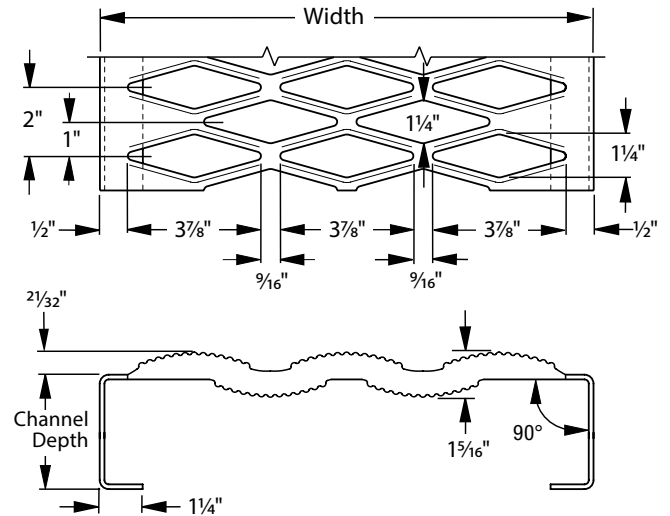
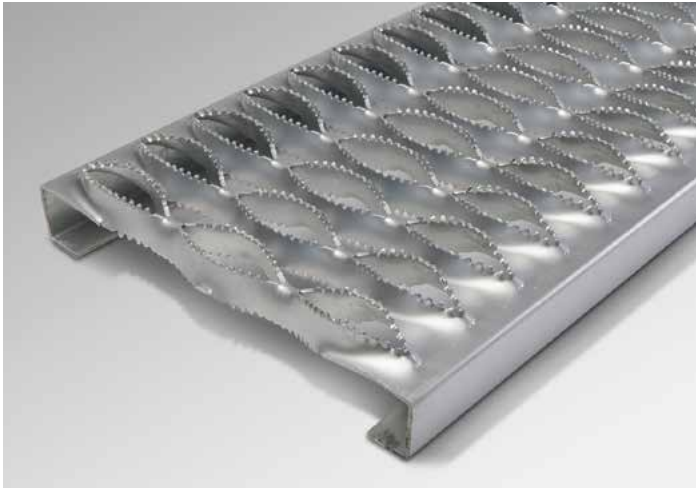

2-DIAMOND PLANK — 9-1/4" WIDE				
Part No.	Width	Channel Depth	Gauge	Weight per LF
<b>10 Ga. Pre-Galvanized Steel*</b>				
H-22010	9-1/4"	2"	10	7.4
H-22510	9-1/4"	2-1/2"	10	7.9
H-23010	9-1/4"	3"	10	8.4
H-24010	9-1/4"	4"	10	10.3

3-DIAMOND PLANK — 13-3/4" WIDE				
Part No.	Width	Channel Depth	Gauge	Weight per LF
<b>10 Ga. Pre-Galvanized Steel*</b>				
H-32010	13-3/4"	2"	10	9.5
H-32510	13-3/4"	2-1/2"	10	10.0
H-33010	13-3/4"	3"	10	10.5
H-34010	13-3/4"	4"	10	11.4

5-DIAMOND PLANK — 23-1/4" WIDE				
Part No.	Width	Channel Depth	Gauge	Weight per LF
<b>10 Ga. Pre-Galvanized Steel*</b>				
H-52010	23-1/4"	2"	10	14.4
H-52510	23-1/4"	2-1/2"	10	14.8
H-53010	23-1/4"	3"	10	15.4
H-54010	23-1/4"	4"	10	16.4

6-DIAMOND PLANK — 27-3/4" WIDE				
Part No.	Width	Channel Depth	Gauge	Weight per LF
<b>10 Ga. Pre-Galvanized Steel*</b>				
H-62010	27-3/4"	2"	10	16.2
H-62510	27-3/4"	2-1/2"	10	16.7
H-63010	27-3/4"	3"	10	17.2
H-64010	27-3/4"	4"	10	18.2

8-DIAMOND PLANK — 36" WIDE				
Part No.	Width	Channel Depth	Gauge	Weight per LF
<b>10 Ga. Pre-Galvanized Steel*</b>				
H-82010	36"	2"	10	19.9
H-82510	36"	2-1/2"	10	20.4
H-83010	36"	3"	10	20.9
H-84010	36"	4"	10	21.8

For additional load table information click link:  
[Heavy Duty Grip Strut Safety Grating](#)

\* To indicate HRPO carbon steel, add the suffix "-B" to the above stated part numbers.  
 Note: 11 gauge and 9 gauge heavy duty grip strut products are available on special order and subject to minimum quantities.



## PERF-O GRIP® SAFETY GRATING

Perf-O Grip is a one-piece metal plank grating manufactured from a single sheet with formed side channels. The perforated buttons provide a walking surface that is slip-resistant in all directions. Open area of approximately 35% allows fluid, ice, and mud to easily flow through the grating. The walking surface of Perf-O Grip has resiliency that cushions footfalls, decreasing worker fatigue and increasing plant productivity.

### Widths & Depths

Perf-O Grip planks are available in a range of widths and depths for various applications and load requirements.

Standard widths include:

- 2-Hole (5" wide)
- 3-Hole (7" wide)
- 5-Hole (10" wide)
- 6-Hole (12" wide)
- 10-Hole (18" wide)
- 13-Hole (24" wide)
- 16-Hole (30" wide)

Standard channel depths are 1-1/2", 2", or 3".

Stock lengths of 10' and 12' are readily available and custom lengths are available on special order.



### Materials

Perf-O Grip planks are available in the following materials:

- Pre-galvanized steel, ASTM A924 G90, 13 or 11 gauge
- HRPO uncoated steel, ASTM A011, 13 or 11 gauge
- 5052 aluminum, ASTM B209, 0.125" thick
- 304 stainless steel, 16 or 14 gauge

## PERF-O GRIP® FASTENERS

### Perf-O Grip Bolt Seat

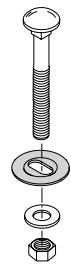

### Perf-O Grip Mid-Support Clip



For additional load table information click link:  
[Perf-O Grip Safety Grating](#)

### How to Order Perf-O Grip

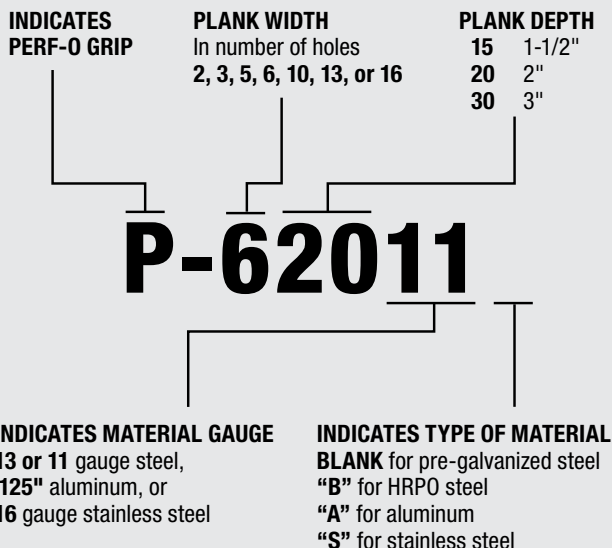

# PERF-O GRIP® SAFETY GRATING

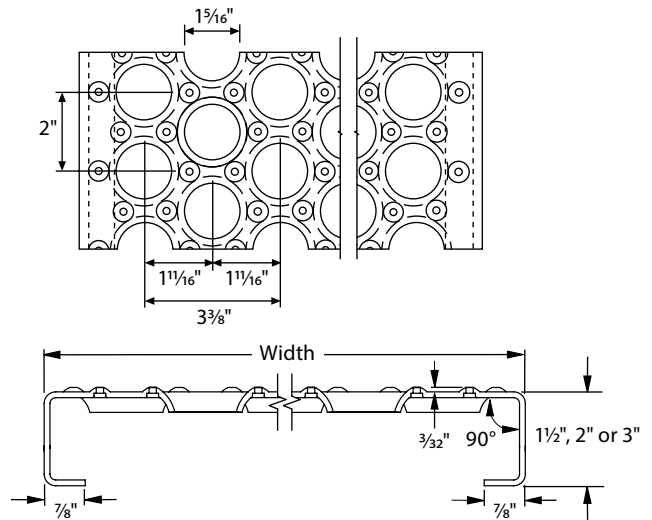

## 2-HOLE PLANK — 5" NOMINAL WIDTH

Part No.	Width	Channel Depth	Gauge	Weight per LF
<b>13 Ga. Pre-Galvanized Steel*</b>				
P-21513	5"	1-1/2"	13	2.6
P-22013	5"	2"	13	2.8
<b>11 Ga. Pre-Galvanized Steel*</b>				
P-21511	5"	1-1/2"	11	3.6
P-22011	5"	2"	11	3.9
<b>.125" 5052 Aluminum</b>				
P-220125-A	5"	2"	.125"	1.3
<b>16 Ga. 304 Stainless Steel</b>				
P-22016-S	5"	2"	16	2.1

## 5-HOLE PLANK — 10" NOMINAL WIDTH

Part No.	Width	Channel Depth	Gauge	Weight per LF
<b>13 Ga. Pre-Galvanized Steel*</b>				
P-51513	10"	1-1/2"	13	3.5
P-52013	10"	2"	13	3.9
<b>11 Ga. Pre-Galvanized Steel*</b>				
P-51511	10"	1-1/2"	11	4.5
P-52011	10"	2"	11	5.1
P-53011	10"	3"	11	5.4
<b>.125" 5052 Aluminum</b>				
P-520125-A	10"	2"	.125"	1.8
<b>16 Ga. 304 Stainless Steel</b>				
P-52016-S	10"	2"	16	3.2

## 10-HOLE PLANK — 18" NOMINAL WIDTH

Part No.	Width	Channel Depth	Gauge	Weight per LF
<b>13 Ga. Pre-Galvanized Steel*</b>				
P-101513	18"	1-1/2"	13	5.7
P-102013	18"	2"	13	6.0
<b>11 Ga. Pre-Galvanized Steel*</b>				
P-101511	18"	1-1/2"	11	6.8
P-102011	18"	2"	11	7.1
P-103011	18"	3"	11	7.9
<b>.125" 5052 Aluminum</b>				
P-1020125-A	18"	2"	0.125	2.79

## 3-HOLE PLANK — 7" NOMINAL WIDTH

Part No.	Width	Channel Depth	Gauge	Weight per LF
<b>13 Ga. Pre-Galvanized Steel*</b>				
P-31513	7"	1-1/2"	13	3.0
P-32013	7"	2"	13	3.3
<b>11 Ga. Pre-Galvanized Steel*</b>				
P-31511	7"	1-1/2"	11	4.2
P-32011	7"	2"	11	4.5
P-33011	7"	3"	11	4.8
<b>.125" 5052 Aluminum</b>				
P-320125-A	7"	2"	.125"	1.5
<b>16 Ga. 304 Stainless Steel</b>				
P-32016-S	7"	2"	16	2.4

## 6-HOLE PLANK — 12" NOMINAL WIDTH

Part No.	Width	Channel Depth	Gauge	Weight per LF
<b>13 Ga. Pre-Galvanized Steel*</b>				
P-61513	12"	1-1/2"	13	4.3
P-62013	12"	2"	13	4.6
<b>11 Ga. Pre-Galvanized Steel*</b>				
P-61511	12"	1-1/2"	11	5.3
P-62011	12"	2"	11	5.5
P-63011	12"	3"	11	6.2
<b>.125" 5052 Aluminum</b>				
P-620125-A	12"	2"	.125"	2.1
<b>16 Ga. 304 Stainless Steel</b>				
P-62016-S	12"	2"	16	3.2

## 13-HOLE PLANK — 24" NOMINAL WIDTH

Part No.	Width	Channel Depth	Gauge	Weight per LF
<b>11 Ga. Pre-Galvanized Steel*</b>				
P-132011	24"	2"	11	8.9
P-133011	24"	3"	11	9.8

## 16-HOLE PLANK — 30" NOMINAL WIDTH

Part No.	Width	Channel Depth	Gauge	Weight per LF
<b>11 Ga. Pre-Galvanized Steel*</b>				
P-162011	30"	2"	11	11.8
P-163011	30"	3"	11	12.7
P-164011	30"	4"	11	13.5

\* To indicate HRPO carbon steel, add the suffix "-B" to the above stated steel part numbers.

For additional load table information click link:  
[Perf-O Grip Safety Grating](#)



## GRATE-LOCK™ SAFETY GRATING

Grate-Lock has interlocking side channels that distribute loads to adjacent planks allowing for longer spans with fewer structural support needs. This allows you to specify lighter gauge steel for substantial material savings. Surface options include slip-resistant traction grip or smooth surface. Pre-punched holes in the side channels allow the installer to bolt the planks together for increased performance.

### Widths & Depths

Grate-Lock planks are available in three easy-to-use plank widths and four plank depths that support a wide range of load requirements.

Available plank widths include:

- 6" wide
- 9" wide
- 12" wide

Standard channel depths are 1-1/2", 2-1/2", 3", and 4".

Stock lengths of 24' are efficient for layout and easily cut-to-size with minimal waste.

\*1-1/2" channel depth only available in 12' length.

### Materials

Grate-Lock Interlocking Planks are available in the following materials:

- Pre-galvanized steel, ASTM A924 G90, 14, 16, & 18 gauge
- HRPO uncoated steel, ASTM A1011 14, 16, & 18 gauge



### Plank Options

- FM for Female-Male
- MM for Male-Male
- FF for Female-Female

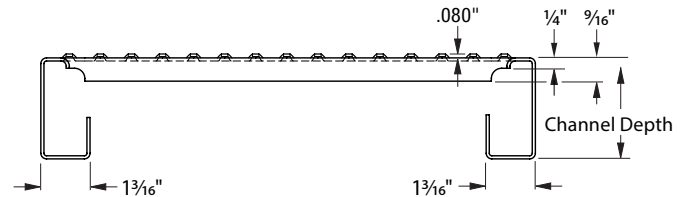
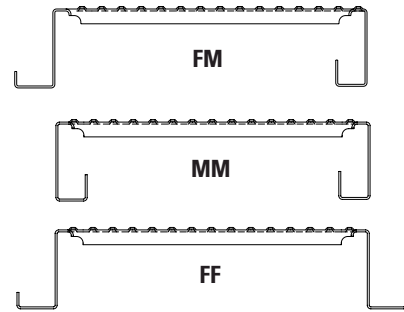

## GRATE-LOCK™ FASTENERS

### Grate-Lock Hold Down Clamp

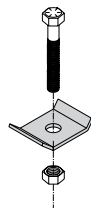

### Grate-Lock Hold Down Clamp

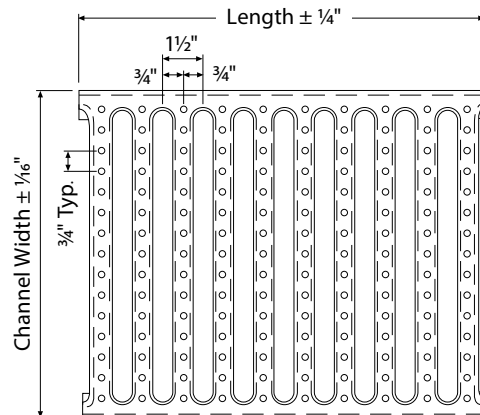
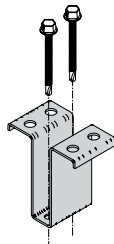

For additional load table information click link:  
[Grate-Lock Interlocking Safety Grating](#)



## How to Order Grate-Lock

**GRATING SURFACE**  
 MG for traction grip  
 MS for smooth surface

**PLANK WIDTHS**  
 6", 9", or 12"

**PLANK HEIGHT**  
 15 1-1/2"  
 25 2-1/2"  
 30 3"  
 40 4"

# MG-122514-FM

**MATERIAL GAUGE**  
 14, 16, or 18 gauge steel

**INTERLOCK DETAIL**  
 FM for Female/Male  
 FF for Female/Female  
 MM for Male/Male

## GRATE-LOCK™ SIZES & OPTIONS

### 6" WIDE GRATE LOCK

Part No.	Width	Channel Depth	Gauge	Weight per LF
<b>14 Ga. Pre-Galvanized Steel</b>				
MG-61514	6"	1-1/2"	14	2.7
MG-62514	6"	2-1/2"	14	3.7
MG-63014	6"	3"	14	3.9
MG-64014	6"	4"	14	4.4
<b>16 Ga. Pre-Galvanized Steel</b>				
MG-61516	6"	1-1/2"	16	2.3
MG-62516	6"	2-1/2"	16	3.1
MG-63016	6"	3"	16	3.2
MG-64016	6"	4"	16	3.0
<b>18 Ga. Pre-Galvanized Steel</b>				
MG-61518	6"	1-1/2"	18	1.9
MG-62518	6"	2-1/2"	18	2.5
MG-63018	6"	3"	18	2.6
MG-64018	6"	4"	18	3.0

### 9" WIDE GRATE LOCK

Part No.	Width	Channel Depth	Gauge	Weight per LF
<b>14 Ga. Pre-Galvanized Steel</b>				
MG-91514	9"	1-1/2"	14	3.5
MG-92514	9"	2-1/2"	14	4.4
MG-93014	9"	3"	14	4.7
MG-94014	9"	4"	14	5.2
<b>16 Ga. Pre-Galvanized Steel</b>				
MG-91516	9"	1-1/2"	16	2.9
MG-92516	9"	2-1/2"	16	3.7
MG-93016	9"	3"	16	3.8
MG-94016	9"	4"	16	4.3
<b>18 Ga. Pre-Galvanized Steel</b>				
MG-91518	9"	1-1/2"	18	2.3
MG-92518	9"	2-1/2"	18	3.0
MG-93018	9"	3"	18	3.1
MG-94018	9"	4"	18	3.5

### 12" WIDE GRATE LOCK

Part No.	Width	Channel Depth	Gauge	Weight per LF
<b>14 Ga. Pre-Galvanized Steel</b>				
MG-121514	12"	1-1/2"	14	4.5
MG-122514	12"	2-1/2"	14	5.2
MG-123014	12"	3"	14	5.4
MG-124014	12"	4"	14	5.9
<b>16 Ga. Pre-Galvanized Steel</b>				
MG-121516	12"	1-1/2"	16	3.5
MG-122516	12"	2-1/2"	16	4.3
MG-123016	12"	3"	16	4.5
MG-124016	12"	4"	16	4.9
<b>18 Ga. Pre-Galvanized Steel</b>				
MG-121518	12"	1-1/2"	18	2.9
MG-122518	12"	2-1/2"	18	3.5
MG-123018	12"	3"	18	3.6
MG-124018	12"	4"	18	4.0

## Surface Options



Available with a standard traction grip "MG" or optional smooth "MS" surface.

For additional load table information click link:  
[Grate-Lock Interlocking Safety Grating](#)



## TRACTION TREAD™ SAFETY GRATING

Traction Tread safety grating features a walking surface with hundreds of perforated buttons that provide slip resistance in all directions. This metal plank grating is manufactured from a single piece of formed metal with side channels. Traction Tread planks are appropriate for commercial and industrial applications, especially inclined ramps, where slip resistance is required.

### Widths & Depths

Traction Tread planks are available in three widths and depths for efficient layout and clear span accommodation.

Standard widths are:

- 7" wide
- 10" wide
- 12" wide

Standard channel depths are 1-1/2", 2" and 3".

Stock lengths of 10' and 12' are readily available.

Custom lengths are available on special order.

### Materials

Traction Tread planks are available in the following materials:

- Pre-galvanized steel, ASTM A924 G90, 11 & 13 gauge
- HRPO uncoated steel, ASTM A1011, 11 & 13 gauge
- 5052 aluminum, 0.125" thick

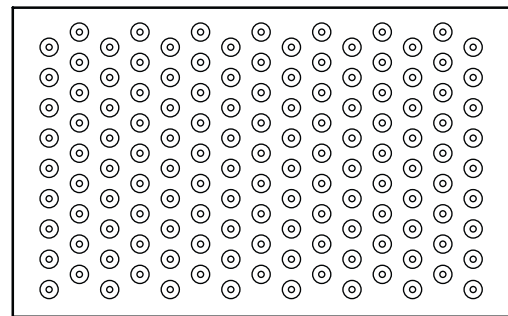

Standard Pattern

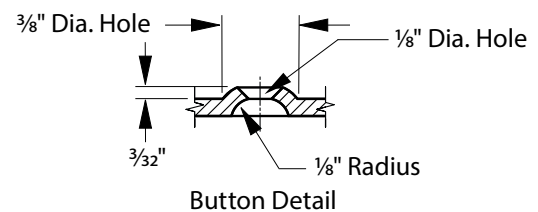

Button Detail

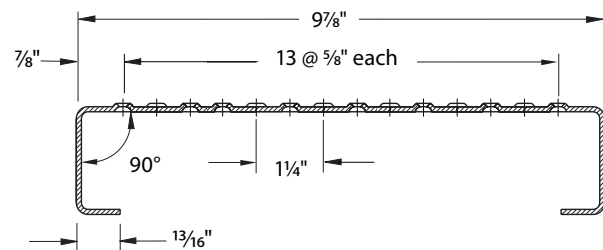

### How to Order Traction Tread

<p>INDICATES TRACTION TREAD</p>	<p>INDICATES WIDTH 7", 10" 12" or Custom Specified</p>	<p>INDICATES CHANNEL DEPTH 15 1-1/2" 20 2" 30 3"</p>
---------------------------------	--	--

TT-122011-GL

<p>INDICATES MATERIAL GAUGE 13 or 11 gauge steel, .125" aluminum, or 16 gauge stainless steel</p>	<p>INDICATES TYPE OF MATERIAL GL for pre-galvanized steel "B" for HRPO steel "A" for aluminum</p>
---	---

For additional load table information click link: [Traction Tread Safety Grating](#)

# TRACTION TREAD™ SAFETY GRATING & LADDER RUNGS



## 7" NOMINAL WIDTH

Part No.	Width	Channel Depth	Gauge	Weight per LF
<b>11 Ga. Pre-Galvanized Steel*</b>				
TT-71511 GL	7"	1-1/2"	11	4.7
TT-72011 GL	7"	2"	11	5.2
TT-73011 GL	7"	3"	11	6.1
<b>13 Ga. Pre-Galvanized Steel*</b>				
TT-71513 GL	7"	1-1/2"	13	3.4
TT-72013 GL	7"	2"	13	3.7
TT-73013 GL	7"	3"	13	4.1
<b>.125" 5052 Aluminum</b>				
TT-715125 AL	7"	1-1/2"	.125"	1.6
TT-720125 AL	7"	2"	.125"	1.8

## 12" NOMINAL WIDTH

Part No.	Width	Channel Depth	Gauge	Weight per LF
<b>11 Ga. Pre-Galvanized Steel*</b>				
TT-121511 GL	12"	1-1/2"	11	6.9
TT-122011 GL	12"	2"	11	7.3
TT-123011 GL	12"	3"	11	8.2
<b>13 Ga. Pre-Galvanized Steel*</b>				
TT-121513 GL	12"	1-1/2"	13	5.0
TT-122013 GL	12"	2"	13	5.3
TT-123013 GL	12"	3"	13	5.9
<b>.125" 5052 Aluminum</b>				
TT-1215125 AL	12"	1-1/2"	.125"	2.4
TT-1220125 AL	12"	2"	.125"	2.5

\* To indicate HRPO carbon steel, replace the suffix "GL" with "B" in the above stated part numbers.

## 10" NOMINAL WIDTH

Part No.	Width	Channel Depth	Gauge	Weight per LF
<b>11 Ga. Pre-Galvanized Steel*</b>				
TT-101511 GL	10"	1-1/2"	11	6.0
TT-102011 GL	10"	2"	11	6.4
TT-103011 GL	10"	3"	11	7.5
<b>13 Ga. Pre-Galvanized Steel*</b>				
TT-101513 GL	10"	1-1/2"	13	4.3
TT-102013 GL	10"	2"	13	4.6
TT-103013 GL	10"	3"	13	5.3
<b>.125" 5052 Aluminum</b>				
TT-1015125 AL	10"	1-1/2"	.125"	2.1
TT-1020125 AL	10"	2"	.125"	2.2

For additional load table information click link:

[Traction Tread Safety Grating](#)

## SAFETY GRATING LADDER RUNGS

Safety Grating Ladder Rungs are available with Traction Tread™ or Grip Strut® surfaces. These slip-resistant ladder rungs are ideal for new ladders or to retrofit existing ladders. Available in multiple widths.

For additional load table information click link:

[Safety Grating Ladder Rungs](#)



### Traction Tread Ladder Rungs

Continuous rows of perforated buttons provide a safe, uniform surface for workers.

Available widths:

- 2-row (1-1/4" wide)
- 3-Row (1-5/8" wide)
- 4-Row (2-1/4" wide)



### Grip Strut Ladder Rungs

Highly serrated diamond matrix provides maximum slip-resistance.

Standard width:

- 1 Diamond (2-1/2" wide)



## SAFETY GRATING FLOOR RESURFACING

Traction Tread Flooring and Grip Strut Reconditioning Material are popular floor resurfacing products. Both products provide the distinct benefits of safety grating; slip resistance, lightweight material, and ease of fabrication.

Floor resurfacing products can be installed over new or existing floors or stairs.

Stock sheets or sheared to size products are available to meet specific project needs.



### Traction Tread Flooring

Traction Tread Flooring has a walking surface with hundreds of perforated buttons providing slip resistance in all directions. The standard staggered button pattern pictured is available from stock and specialty patterns are available on special order.

Stock sheet size is 36" x 120" and can be sheared to size per customer specification.

Available in 11, 13, and 16 gauge carbon steel, 14 gauge stainless steel, or .125" thick aluminum.



### Grip Strut Reconditioning Material

The standard Grip Strut serrated, open-diamond matrix walking surface provides maximum slip resistance when Grip Strut Reconditioning Material is selected. Popular for uses where liquids and lubricants commonly spill onto floors or platforms.

Standard widths include 6-1/4, 8-9/16, 10-7/8, 13-3/16, 20-1/8, and 24-3/4 inches.

Available in 12 or 14 gauge carbon steel, 16 gauge stainless steel, or .100" and .080" thick aluminum.

GRIP STRUT RECONDITIONING MATERIAL						
Dim.	2-Dia.	3-Dia.	4-Dia.	5-Dia.	8-Dia.	10-Dia.
W1	5-3/16"	7-1/2"	9-13/16"	12-1/8"	19-1/6"	23-11/16"
W2	6-1/4"	8-9/16"	10-7/8"	13-3/16"	20-1/8"	24-3/4"

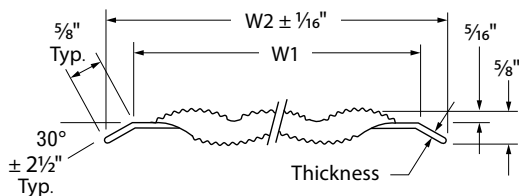

TRACTION TREAD FLOORING		
Gauge/Thickness	Catalog Number	Weight/SF
<b>HRPO Carbon Steel or Pre-Galvanized Steel</b>		
11 gauge	TT-3611*	5.0 lbs.
13 gauge	TT-3613*	3.8 lbs.
16 gauge	TT-3616*	2.5 lbs.
*Add -B to catalog # for HRPO products		
<b>Aluminum Alloy 5052-H32</b>		
0.125"	TT-36.125-A	1.6 lbs.
<b>304 Stainless Steel</b>		
16 gauge	TT-3616-SS	2.7 lbs.

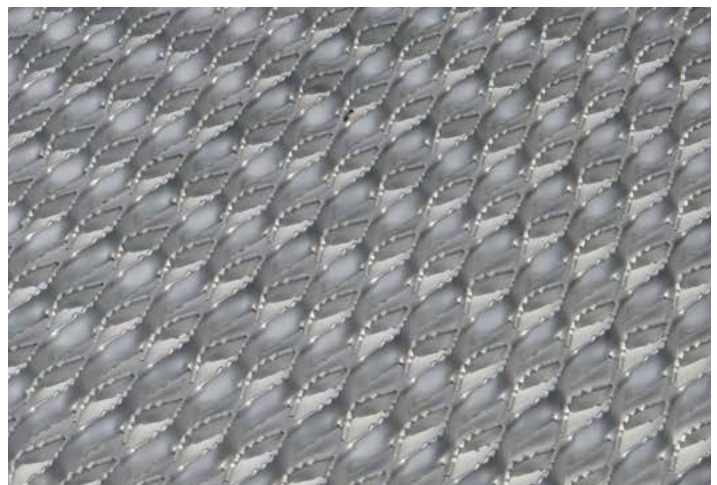

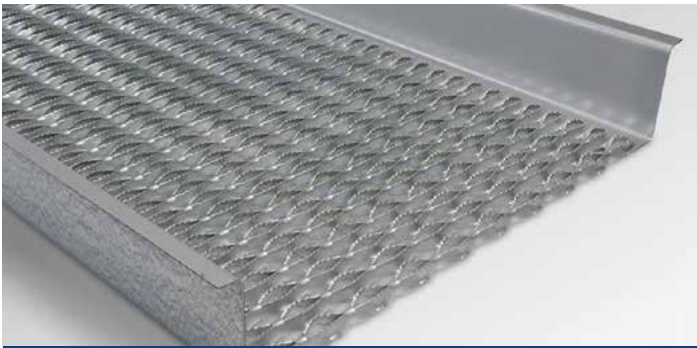

## GRIP STRUT WALKWAY CHANNEL

Width	Part No.	Material
10-Diamond 24"	<b>104514-U</b>	14 ga. Steel
24"	<b>104512-U</b>	12 ga. Steel

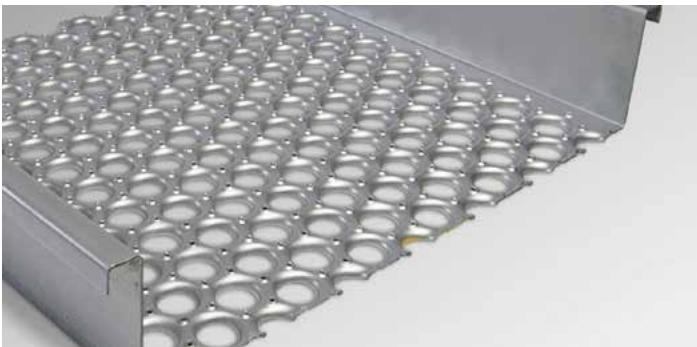

## PERF-O GRIP WALKWAY CHANNEL

Width	Part No.	Material
13-Hole 24"	<b>P-135011-W</b>	Pre-galvanized or HRPO 11 ga. Steel
16-Hole 30"	<b>P-165011-W</b>	
20-Hole 36"	<b>P-205011-W</b>	

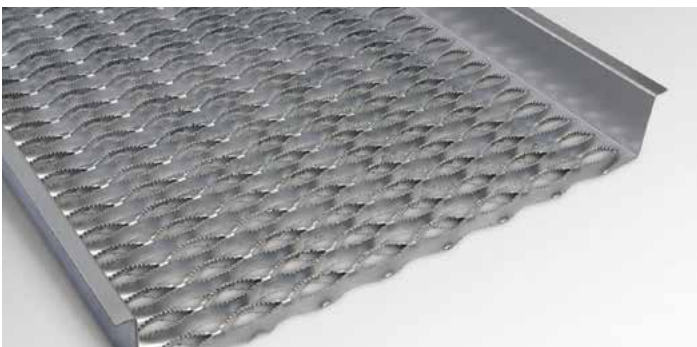

## HEAVY DUTY GRIP STRUT WALKWAY CHANNEL

Width	Part No.	Material
5-Diamond 24"	<b>H-55010-W</b>	Pre-galvanized or HRPO 10 ga. Steel <i>9 ga. or 11 ga. steel available on special order</i>
6-Diamond 30"	<b>H-65010-W</b>	
8-Diamond 36"	<b>H-85010-W</b>	

## Grip Strut Walkway Channels

Grip Strut walkway channels use the same open diamond matrix as standard Grip Strut planks. This safe walking surface allows for draining of liquids, passage of debris, and excellent slip resistance in all directions.

Grip Strut Walkway features:

- 10-Diamond 24" width
- 4-1/2" side toe board
- Pre-galvanized or HRPO, 14 or 12 gauge steel

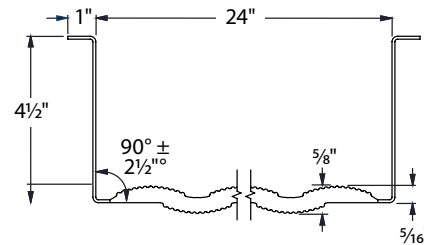

## Perf-O Grip Walkway Channels

Perf-O Grip walkway channels have large debossed holes surrounded by slip-resistant perforated buttons. Like Perf-O Grip planks, the resilient walking surface also cushions footfalls which reduces worker fatigue.

Perf-O Grip Walkway features:

- 24" and 30" widths (36" width available on special order)
- 5" side toe board
- Pre-galvanized or HRPO 11 gauge steel

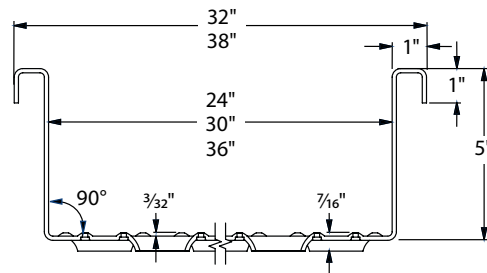

## Heavy Duty Grip Strut Walkway Channels

Using the larger, heavily serrated diamond matrix of Heavy Duty Grip Strut, these walkway channels are manufactured from thicker steel which allows for longer unsupported spans.

Heavy Duty Grip Strut Walkway features:

- 24", 30", and 36" widths
- 5" side toe board

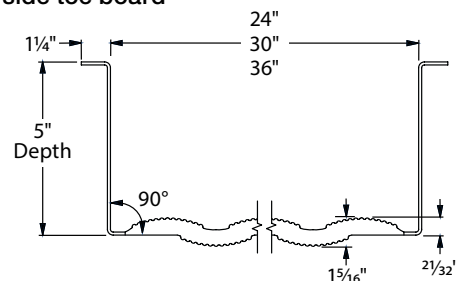

For additional load table information click link:  
[Safety Grating Walkway Channels](#)



# SAFETY GRATING STAIR TREADS



## GRIP STRUT STAIR TREADS SIDE MARGIN NOSING

Width	Depth	Material
2-Diamond 4-3/4"	1-1/2" or 2"	Pre-Galvanized Carbon Steel 14 ga or 12 ga
3-Diamond - 7"		
4-Diamond - 9-1/2"		
5-Diamond - 11-3/4"		
2-Diamond 4-3/4"	2"	Aluminum 0.080 or 0.100
3-Diamond - 7"		
4-Diamond - 9-1/2"		
5-Diamond - 11-3/4"	2"	Stainless Steel 16 ga. Type 316L or 304L
4-Diamond - 9-1/2"		
5-Diamond - 11-3/4"		



## GRIP STRUT STAIR TREADS CAST ABRASIVE NOSING

Width	Depth	Material
3-Diamond - 8-1/8"	1-1/2" or 2"	Pre-Galvanized Carbon Steel 14 ga or 12 ga
4-Diamond - 10-1/2"		
3-Diamond - 8-1/8"	2"	Aluminum 0.080 or 0.100
4-Diamond - 10-1/2"		



## GRATE-LOCK STAIR TREADS

Nosing	Widths	Depth	Material
Optional Checker Plate	6", 9", or 12"	2-1/2" Channel Depth	Pre-galvanized Carbon Steel, 14 ga.



## PERF-O GRIP STAIR TREADS

Widths	Depths	Material
2-Hole - 5"	1-1/2" or 2" Channel Heights*	Pre-galvanized Carbon Steel, 11 ga. or 13 ga., 5052-H32 Aluminum 0.125" thick
3-Hole - 7"		
5-Hole - 10"		
6-Hole - 12"		

\* 2" Channel Height 0.125" Aluminum 5052-H32



## HEAVY DUTY GRIP STRUT STAIR TREADS

Width	Depth	Material
2-Diamond 9-1/4"	2"	Pre-galvanized 10 ga.



## TRACTION TREAD STAIR TREADS

Widths	Depths	Material
7", 10" & 12"	1-1/2" or 2" Channel Heights	Pre-galvanized Carbon Steel, 11 ga. or 13 ga., 5052-H32 Aluminum 0.125" thick

For additional load table information click link:  
[Safety Grating Stair Treads](#)

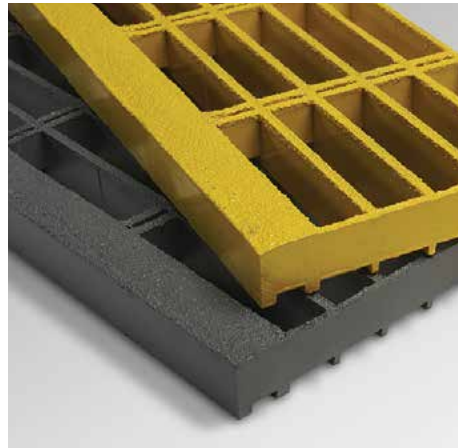

# FIBERGLASS GRATING

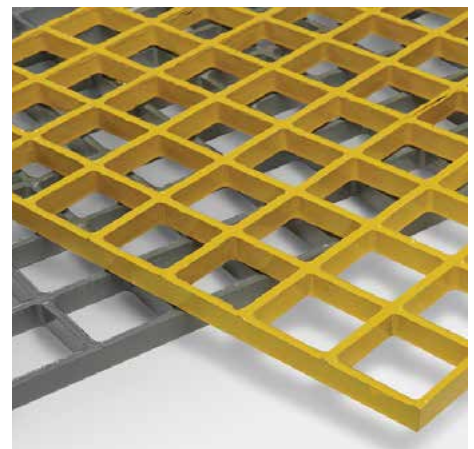



## FIBERGLASS GRATING

Available in a wide range of high-performance resins, fiberglass gratings and structural components are preferred for demanding applications including chemical processing, marine environments, pulp and paper plants, food and beverage processing, and wastewater facilities. Features that make fiberglass a preferred option include:

- Excellent corrosion resistance
- Fire retardant
- Lightweight & easily fabricated
- Low maintenance
- Long service life



## Fiberglass Grating Products

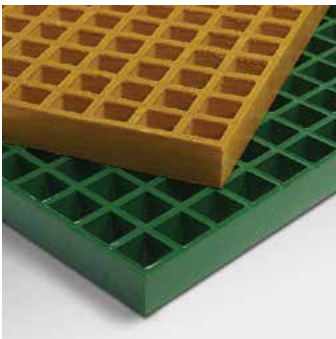

**Molded Fiberglass Grating**



**Safe-T-Span® Pultruded Fiberglass Grating**

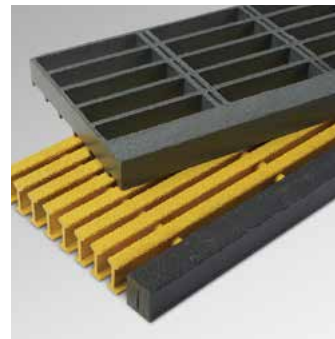

**Fiberglass Stair Treads**



**Fiberplate Stair Tread Covers**

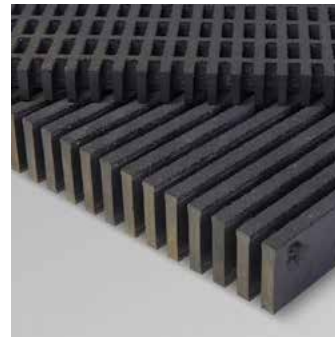

**High Load Capacity Fiberglass Grating**

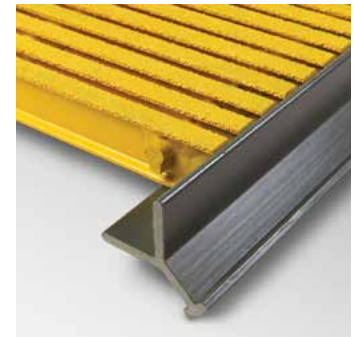

**Fiberglass Grating Embed Angle**



**Dynaform® FRP Structural Shapes & Fabrication**

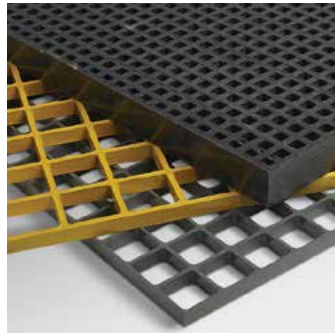

**Molded Fiberglass Patterns & Screens**

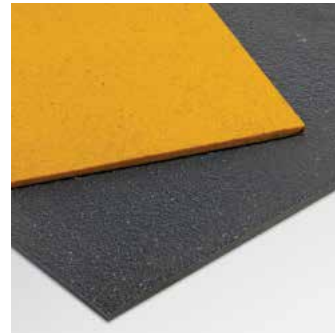

**FRP Floor Plate**

## MOLDED FIBERGLASS GRATING

Manufactured by combining thermosetting resin with continuous fiberglass rovings in precision molds, each panel contains approximately 65% resin and 35% fiberglass rovings. This combination optimizes corrosion resistance, UV protection, and structural integrity. Popular resins include economical Corvex polyester and superior Vi-Corr vinyl ester, with additional options available based on the needs of the application.

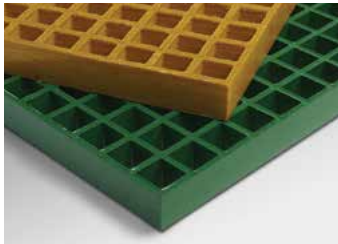

### Molded Square Mesh

The square pattern of the panels provides bi-directional strength and facilitates easy layout and fabrication. Available with a standard concave meniscus surface or optional grit surface.



### Molded Rectangular Mesh

Available in a 1" deep, 1" x 4" pattern. When selecting rectangular mesh grating it is important to specify the span (rectangular opening) of the grating perpendicular to the supporting structure. Available with a standard concave meniscus surface or optional grit surface.

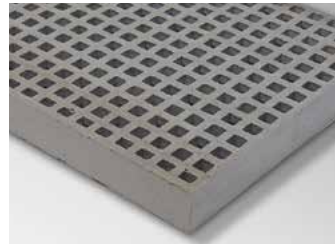

### Micro-Mesh® Molded Grating

With a 1/2" square opening, this grating is ideal for applications in the public way. Bi-directional strength facilitates efficient layout and fabrication. Surface options are concave meniscus, smooth (sanded) surface, or coarse or fine grit surfaces.



### Ecograte® 62

ADA compliant and specifically designed to meet requirements of the National Marine Fisheries Service and U.S. Army Corps of Engineers for marine decking and docks. This grating has a 62% open area. Surface options include a standard coarse grit walking surface or the optional Aqua Grit (fine grit) surface for increased comfort under bare feet.

## SAFE-T-SPAN PULTRUDED FIBERGLASS GRATING

Manufactured with approximately 70% fiberglass rovings and 30% resin, pultruded gratings safely support industrial and pedestrian loads on longer spans. Pultruded grating features "I" bar and "T" bar profiles, is fire retardant, meeting both ASTM E84 and ASTM D635, and has a standard slip-resistant quartz grit walking surface.



I-6015 1-1/2" I-Bar



T-5020 2" T-Bar



T-3810 1" T-Bar



T-1810 1" T-Bar

### Safe-T-Span® Industrial Pultruded Gratings

### Safe-T-Span® Pedestrian Grating

### Aqua Grate® Pedestrian Grating

## HIGH LOAD CAPACITY (HLC) FIBERGLASS GRATING

Ideal for trench covers, ramps, or inlet covers, HLC fiberglass grating is produced in both molded and pultruded configurations. Engineered and manufactured to support vehicular and forklift traffic in corrosive environments. All high load panels have a Class 1 Fire Rating with an ASTM E84 flame spread rating of 25 or less.



### Molded HLC Grating

Manufactured with a 1" x 2" rectangular mesh, molded HLC products are available in 1-1/2" or 2" depths.



### Safe-T-Span HLC Fiberglass Grating

Depths ranging from 1" to 3" with open area ranging from 37% to 58%, pultruded HLC products are rated for loads up to H-20 truck traffic.



## MOLDED FIBERGLASS GRATING SIZES & OPTIONS

### 1" DEEP 1-1/2" SQUARE MESH

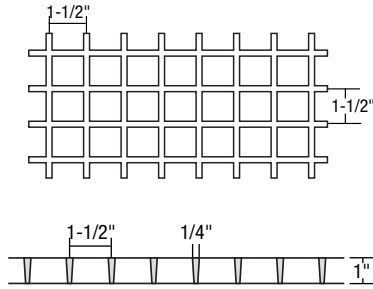

LOAD BAR WIDTH 1/4" ±  
LOAD BAR CENTERS 1-1/2"  
CROSS BAR CENTERS 1-1/2"  
OPEN AREA 70%  
WEIGHT/SQ. FT. 2.5 LBS.

Depth	Mesh	Panel Size	Weight	Resins	Colors
1"	1-1/2" Square	3' x 10'	75#	Corvex, VI-Corr, FGI-AM	Green, Yellow, Dark Gray, Light Gray, Orange
1"	1-1/2" Square	4' x 8'	80#		
1"	1-1/2" Square	4' x 12'	120#		

### 2" DEEP 2" SQUARE MESH

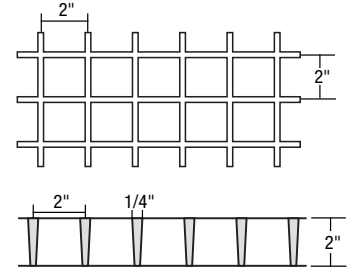
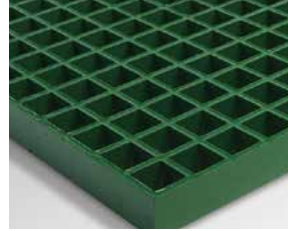

LOAD BAR WIDTH 1/4" ±  
LOAD BAR CENTERS 2"  
CROSS BAR CENTERS 2"  
OPEN AREA 72%  
WEIGHT/SQ. FT. 4.0 LBS.

Depth	Mesh	Panel Size	Weight	Resins	Colors
2"	2" Square	4' x 12'	192#	Corvex	Green, Yellow, Dark Gray, Light Gray, Orange

### 1" DEEP 1" X 4" RECTANGULAR MESH

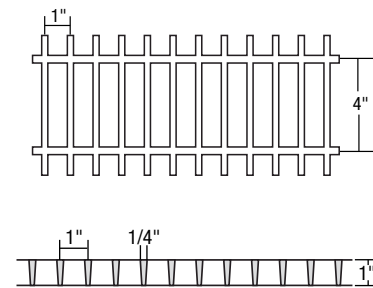

LOAD BAR WIDTH 1/4" ±  
LOAD BAR CENTERS 1"  
CROSS BAR CENTERS 4"  
OPEN AREA 69%  
WEIGHT/SQ. FT. 2.5 LBS.

Depth	Mesh	Panel Size	Weight	Resins	Colors
1"	1" x 4" Rect.	3' x 10'	75#	Corvex, VI-Corr, FGI-AM	Green, Yellow, Dark Gray, Light Gray, Orange
1"	1" x 4" Rect.	4' x 8'	80#		

### MICRO-MESH® - 3/4" SQUARE MESH

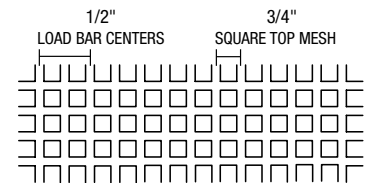
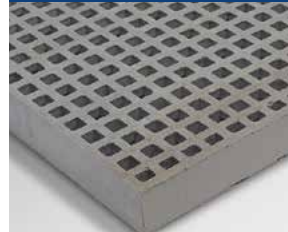

Section Properties per Ft. of Width: A=2.34 IN<sup>2</sup> I=0.23 IN<sup>4</sup> S=0.37 IN<sup>3</sup>

Section Properties per Ft. of Width: A=2.85 IN<sup>2</sup> I=0.51 IN<sup>4</sup> S=0.65 IN<sup>3</sup>

Depth	Mesh	Panel Size	Weight	Resins	Colors
1"	3/4" Square	4' x 12'	139#	Corvex	Light Gray
1-1/2"	3/4" Square	4' x 12'	216#		

### 1-1/2" DEEP 1-1/2" SQUARE MESH

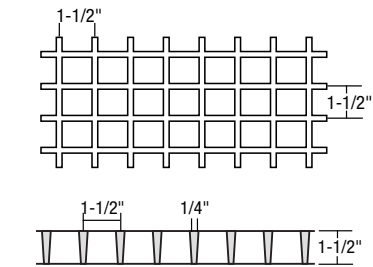
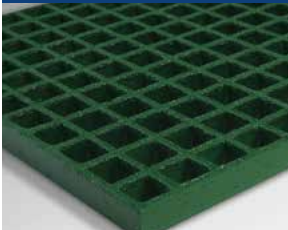

LOAD BAR WIDTH 1/4" ±  
LOAD BAR CENTERS 1-1/2"  
CROSS BAR CENTERS 1-1/2"  
OPEN AREA 70%  
WEIGHT/SQ. FT. 3.75 LBS.

Depth	Mesh	Panel Size	Weight	Resins	Colors
1-1/2"	1-1/2" Square	3' x 10'	113#	Corvex, VI-Corr, FGI-AM	Green, Yellow, Dark Gray, Light Gray, Orange
1-1/2"	1-1/2" Square	4' x 8'	120#		
1-1/2"	1-1/2" Square	5' x 10'	188#		
1-1/2"	1-1/2" Square	4' x 12'	180#		

### ECOGRATE®62 - 1" DEEP 3/4" X 4" RECTANGULAR MESH

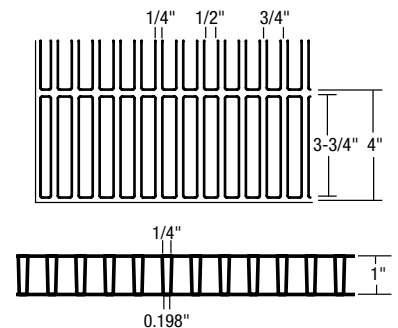

LOAD BAR WIDTH 1/4" ±  
LOAD BAR CENTERS 3/4"  
CROSS BAR CENTERS 4"  
OPEN AREA 62%  
WEIGHT/SQ. FT. 3.0 LBS.

Depth	Mesh	Panel Size	Weight	Resins	Colors
1"	3/4" x 4"	4' x 8'	96#	Corvex	Dark Gray, Light Gray
		4' x 10'	120#		
		4' x 12'	144#		

All products are available in the full range of resin and colors indicated on our Resins & Colors chart. Specialty patterns and alternative depths are also available. Please contact us for additional information.

## Molded Fiberglass Grating Resins & Colors

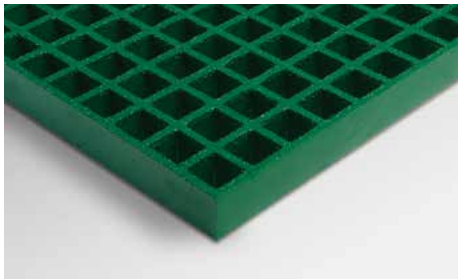

### Corvex®

Isophthalic polyester resin system. Meets the requirements for corrosion resistance found in industrial, chemical processing, and water/wastewater applications.

**Flame Spread:** ASTM E84 rating of 25 or less.

**Standard Colors:** Yellow, Light Gray, Dark Gray, or Green.

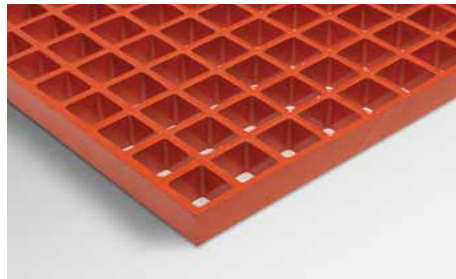

### Vi-Corr®

Superior vinyl ester resin. Offers outstanding resistance to a wide range of highly corrosive situations, from caustic to acidic.

**Flame Spread:** ASTM E84 rating of 25 or less.

**Standard Colors:** Yellow, Light Gray, Dark Gray, Orange, or Green.



### FGI-AM®

Food-grade isophthalic polyester resin system offers antimicrobial properties to inhibit the growth of bacteria on the surface of the composite to protect the product itself.

**Flame Spread:** ASTM E84 rating of 25 or less.

**Standard Colors:** Light Gray, or Green.

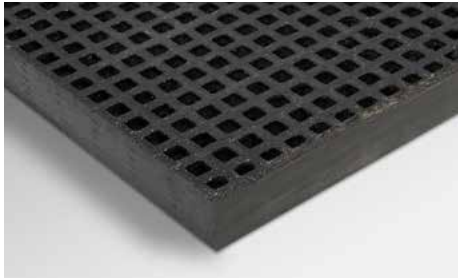

### XFR

Extra fire-retardant vinyl ester resin is recommended for use where fire potential is high.

**Flame Spread:** ASTM E84 rating of 10 or less.

**Standard Color:** Dark Gray.

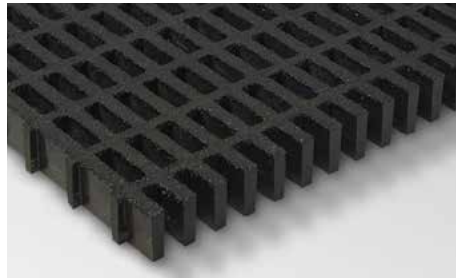

### ELS

Acrylic-modified, low smoke polyester resin ideal for tunnel, offshore, mass transit, and other confined space applications.

**Flame Spread:** ASTM E84: flame spread index of 25 or less, a smoke developed index of 100 or less and Fuel Contribution of 0.

**Certifications:** DNV GL Type Approval No. TAF000003C; meets the USCG requirements for general fire rating.

**Standard Color:** Dark Gray.



### Super Vi-Corr®

This family of resin systems consists of more than 30 custom formulas engineered to provide corrosion control solutions in applications that are too severe for conventional FRP and other building materials.

**Flame Spread:** Non fire retardant, unless specified.

**Standard Color:** Natural – tan to beige.

## Molded Fiberglass Grating Surface Options

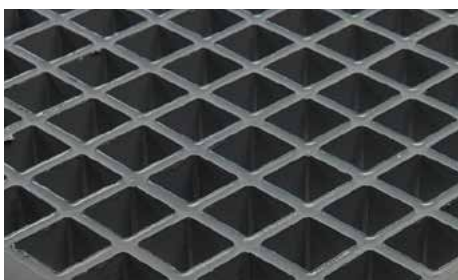

### Meniscus Surface

Slip-resistant concave meniscus surface on the top of the bearing bars.

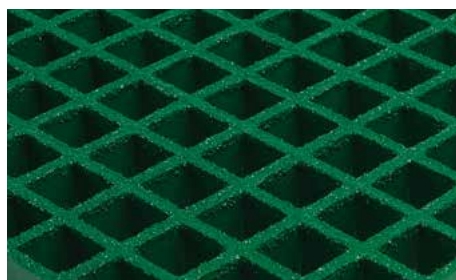

### Standard Coarse Grit

Integrally applied coarse grit provides increased slip-resistance for industrial applications.



### Aquagrit

Optional fine grit surface preferred for barefoot traffic on docks or recreational applications. Also known as sugar grit.



# FIBERGLASS GRATING

## SAFE-T-SPAN PULTRUDED FIBERGLASS GRATING SIZES & OPTIONS

All products are provided with tie bars at 6" on center. Standard walking surface is slip-resistant coarse grit. Stock resins are ISOFR and VEFR in yellow or gray.

### 1" DEEP INDUSTRIAL GRATING

1" Deep, I-6010

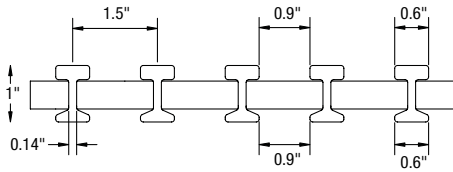

1" DEEP, I-4010 ADA COMPLIANT

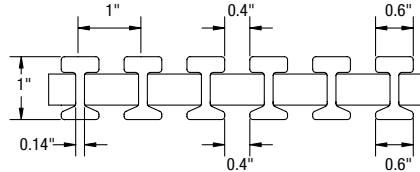

Part No.	Depth	Load Bar Spacing	Widths	Lengths	Weight (psf)	Open Area
I-6010	1"	1.5" O.C.	36" or 48"	Up to 24'-0"	2.6#	60%
I-4010	1"	1" O.C.	36" or 48"	Up to 24'-0"	4.1#	40%

### 1-1/2" DEEP INDUSTRIAL GRATING

1-1/2" DEEP, I-6015

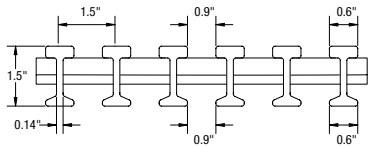

1-1/2" DEEP, I-4015 ADA COMPLIANT

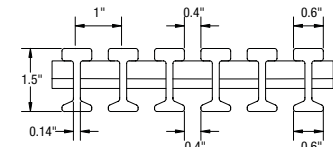

Part No.	Depth	Load Bar Spacing	Widths	Lengths	Weight (psf)	Open Area
I-6015	1-1/2"	1.5" O.C.	36" or 48"	Up to 24'-0"	2.8#	60%
I-4015	1-1/2"	1" O.C.	36" or 48"	Up to 24'-0"	4.1#	40%

### 2" DEEP INDUSTRIAL GRATING

2" DEEP, T-5020

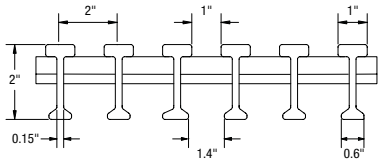

2" DEEP, T-3320 ADA COMPLIANT

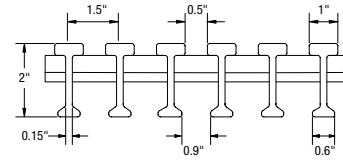

Part No.	Depth	Load Bar Spacing	Widths	Lengths	Weight (psf)	Open Area
T-5020	2"	2" O.C.	36" or 48"	Up to 24'-0"	3.1#	50%
T-3320	2"	1-1/2" O.C.	36" or 48"	Up to 24'-0"	4.0#	33%

## AQUA GRATE® FRP PEDESTRIAN GRATING

Tie bar spacing is at 6" on center. Standard walking surface is Aquagrit slip-resistant fine grit. Standard colors are dark gray bar w/ light gray top coat.

### 1" AND 1-1/2" DEEP PEDESTRIAN GRATING

1" DEEP, T-1210 ADA COMPLIANT

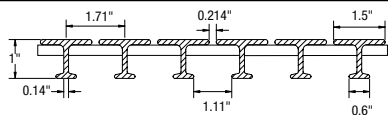

1-1/2" DEEP, T-1215 ADA COMPLIANT

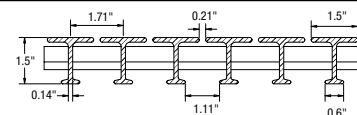

Part No.	Depth	Load Bar Spacing	Widths	Lengths	Weight (psf)	Open Area
T-1210	1"	1.71" O.C.	36" or 48"	Up to 24'-0"	2.6#	12%
T-1215	1-1/2"	1.71" O.C.	36" or 48"	Up to 24'-0"	3.6#	12%

## SAFE-T-SPAN® FRP PEDESTRIAN GRATING

Tie bar spacing is at 6" on center. Standard walking surface is Aquagrit slip-resistant fine grit. Stock resins are ISOFR or VEFR dark gray.

### 1" DEEP PEDESTRIAN GRATING

1" DEEP, T-3810

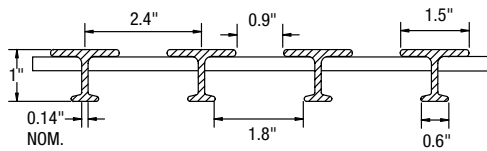

1" DEEP, T-2510 ADA COMPLIANT

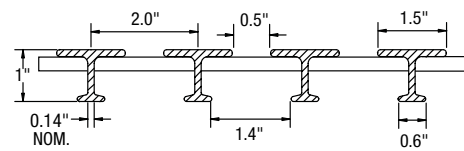

Part No.	Depth	Load Bar Spacing	Widths	Lengths	Weight (psf)	Open Area
T-3810	1"	2.4" O.C.	36" or 48"	Up to 24'-0"	1.9#	38%
T-2510	1"	2" O.C.	36" or 48"	Up to 24'-0"	2.3#	25%

### 1-1/2" DEEP PEDESTRIAN GRATING

1-1/2" DEEP, T-3815

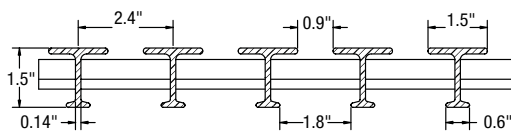

1-1/2" DEEP, T-2515 ADA COMPLIANT

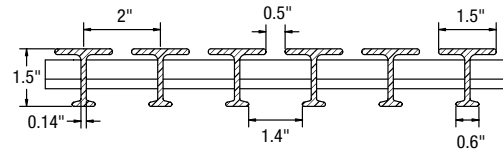

Part No.	Depth	Load Bar Spacing	Widths	Lengths	Weight (psf)	Open Area
T-3815	1-1/2"	2.4" O.C.	36" or 48"	Up to 24'-0"	2.7#	38%
T-2515	1-1/2"	2" O.C.	36" or 48"	Up to 24'-0"	3.2#	25%

## Safe-T-Span Pultruded Fiberglass Grating Resins & Colors



### ISOFR

Isophthalic polyester resin with a low flame spread rating of 25 or less designed for applications where there is moderate exposure to corrosive elements (DNV Type Approval Certificate F-16856).

**Flame Spread:** ASTM E84 rating of 25 or less.

**Standard Colors:** Yellow or dark gray.

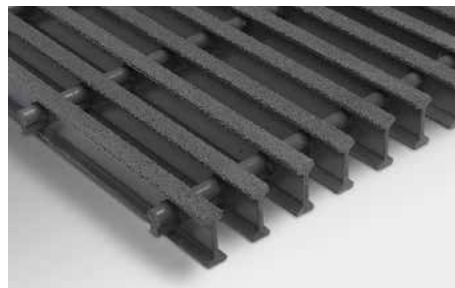

### VEFR

Vinyl ester resin system with a flame spread rating of 25 or less for dependable resistance to both acidic and alkaline environments

**Flame Spread:** ASTM E84 rating of 25 or less.

**Standard Colors:** Yellow or dark gray.



### PHENOLIC

Coast Guard approved flame-resistant phenolic resin with an extremely low flame spread rating of 10 and a smoke index of 400 (unpainted); flame spread of 15 and a smoke index of 450 (painted, UV coating) – designed primarily for the offshore industry. (Coast Guard approved for Level 2 & 3 performance criteria – Approval Number: 164.040/2/2; DNV GL Type Approval No. TAF000003C; ABS Product Type Approval Level 2 & 3 Certificate No. 01-HS34733-X)

**Standard Colors:** Natural/orange.



### Standard Coarse Grit

Integrally applied coarse grit provides increased slip-resistance for industrial applications.



### Aquagrit

Optional fine grit surface preferred for barefoot traffic on docks or recreational applications. Also known as sugar grit.

For additional load table information click link:

[Safe-T-Span Pultruded Fiberglass Grating](#)



# FIBERGLASS GRATING

## HIGH LOAD CAPACITY (HLC) FIBERGLASS GRATING



### Molded HLC Fiberglass Grating

Manufactured with a 1" x 2" rectangular mesh, molded HLC products are available in 1-1/2" or 2" depths.

#### HLC 1-1/2" DEEP X 1" X 2" RECTANGULAR MESH

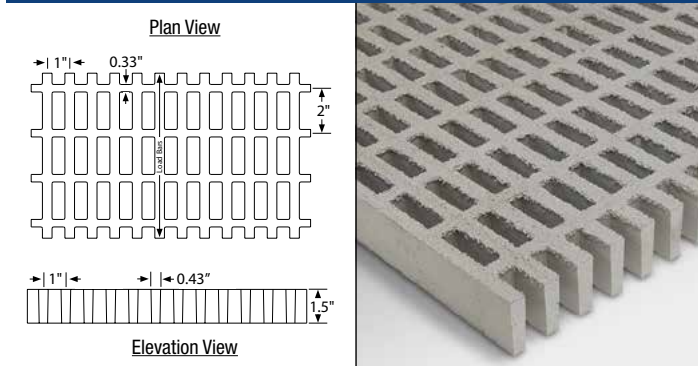

# of Bars/ Ft of Width	Load Bar Width	Open Area	Load Bar Centers	Approx. Wt.
12	0.43"	48%	1"	6.2 psf

Section Properties per Ft of Width: A = 7.45 IN<sup>2</sup> | I = 1.39 IN<sup>4</sup> S = 1.80 IN<sup>3</sup>

#### HLC 2" DEEP X 1" X 2" RECTANGULAR MESH

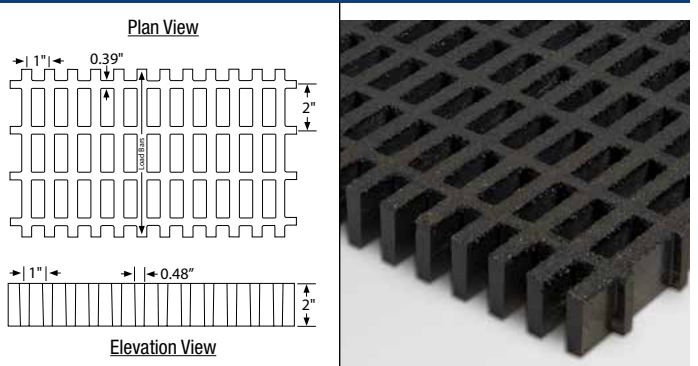

# of Bars/ Ft of Width	Load Bar Width	Open Area	Load Bar Centers	Approx. Wt.
12	0.48"	48%	1"	8.4 psf

Section Properties per Ft of Width: A = 10.26 IN<sup>2</sup> | I = 3.4 IN<sup>4</sup> S = 3.27 IN<sup>3</sup>

### Safe-T-Span Pultruded HLC Grating

Produced in depths ranging from 1" to 3" with open area ranging from 37% to 58%, pultruded HLC products are rated for loads up to H-20 truck traffic.

#### HI47 SERIES

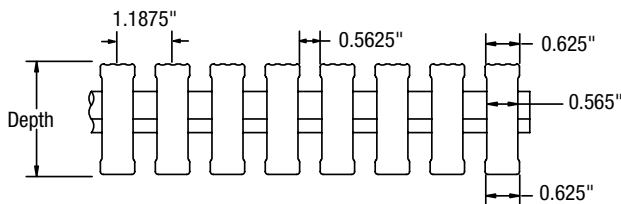

Load Bar Depth	Open Area	Load Bar Centers	Approx. Weight
1"	47%	1.1875"	5.5 lb/ft <sup>2</sup>
1-1/2"	47%	1.1875"	8 lb/ft <sup>2</sup>
2"	47%	1.1875"	10.9 lb/ft <sup>2</sup>
2-1/2"	47%	1.1875"	12.3 lb/ft <sup>2</sup>
3"	47%	1.1875"	14.7 lb/ft <sup>2</sup>

For additional load table information click link:  
[High Load Capacity Fiberglass Grating](#)

#### HI37 SERIES

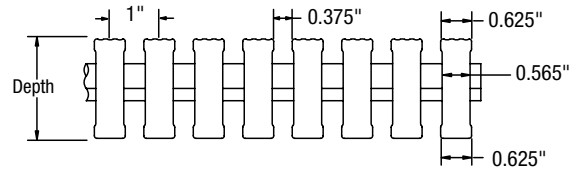

Load Bar Depth	Open Area	Load Bar Centers	Approx. Weight
1"	37%	1"	6.5 lb/ft <sup>2</sup>
1-1/2"	37%	1"	9.6 lb/ft <sup>2</sup>
2"	37%	1"	13 lb/ft <sup>2</sup>
2-1/2"	37%	1"	14.8 lb/ft <sup>2</sup>
3"	37%	1"	17.7 lb/ft <sup>2</sup>

#### HI58 SERIES

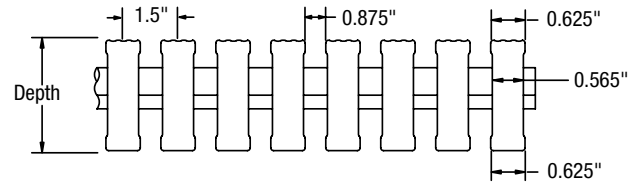

Load Bar Depth	Open Area	Load Bar Centers	Approx. Weight
1"	58%	1.5"	4.3 lb/ft <sup>2</sup>
1-1/2"	58%	1.5"	6.5 lb/ft <sup>2</sup>
2"	58%	1.5"	8.7 lb/ft <sup>2</sup>
2-1/2"	58%	1.5"	10 lb/ft <sup>2</sup>
3"	58%	1.5"	12 lb/ft <sup>2</sup>

## FIBERGLASS STAIR TREADS & STAIR COVERS

Fiberglass stair treads and stair covers are an essential complement to molded and pultruded grating installations. Designed to meet or exceed OSHA requirements and building code standards, fiberglass stair treads and covers are:

- Slip-resistant
- Fire retardant
- Non-conductive
- Low maintenance
- Easily fabricated in the shop or field



### Fiberglass Treads & Stair Covers



#### Molded FRP Stair Treads

One-piece molded stair treads are 1-1/2" deep with a 1-1/2" x 6" mesh and a solid, visibly defined, slip-resistant nosing. The grating portion of the tread is available with the standard meniscus or optional grit surface.



#### Pultruded FRP Stair Treads

Designed with "I" or "T" shaped bearing bars, these treads provide superior strength for walkways that require longer spans. Standard colors: yellow grating with dark gray nosing, or dark gray grating with yellow nosing.

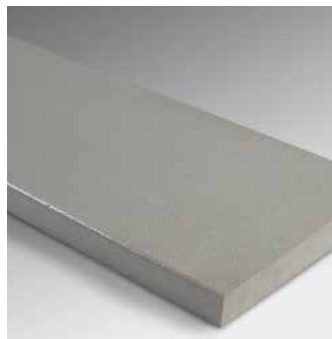

#### Covered Fiberglass Stair Treads

Designed as an alternative to concrete or metal steps, covered stair treads are designed for uses such as universities, commercial office parks, motels, and aquatic or amusement parks.



#### FRP Stair Covers

Fiberglass stair tread covers are manufactured with an integral aluminum grit walking surface and visible nosing of contrasting color. They can be installed over wood, concrete, or metal steps.

## FIBERGLASS GRATING FASTENERS



Type "M" Saddle Clip



Type "J" Hold Down Clip



Type "F" End Panel Clip



Type "E" Hold Down Clip



Type "FC" Hold Down Clip



Type "G" Friction Clip



Type "W" Clip



Type "WLP" Clip



## SPECIALTY FIBERGLASS PATTERNS & SCREENS

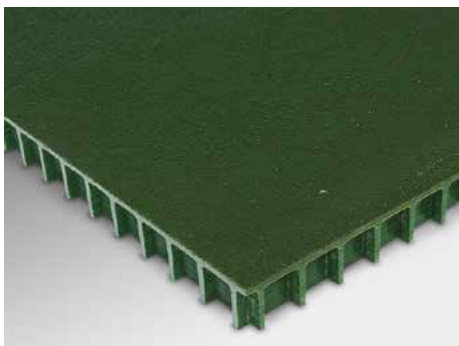

### Covered Molded Grating

All molded gratings are available with a solid 1/8" or 1/4" thick fiberglass plate applied to the top surface of the grating. Popular in loading or storage areas, the solid surface prevents the passage of contaminants or debris to areas below. Covered gratings are also an excellent choice for odor control applications.

Available in all resins with smooth, coarse grit, or fine grit surfaces.

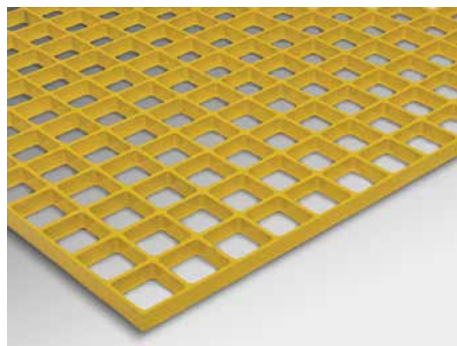

### AirMesh® Screening

Specifically designed to meet US Navy requirements for air intake screens, AirMesh is 1/2" deep with 1/8" thick bars spaced 1-1/2" on center. With 87% open area, AirMesh serves marine and general industrial applications where generous airflow and screening is important. Standard sheet size is 4' x 8' in yellow, green, or dark gray.

Weight per square foot: 0.8 lbs.

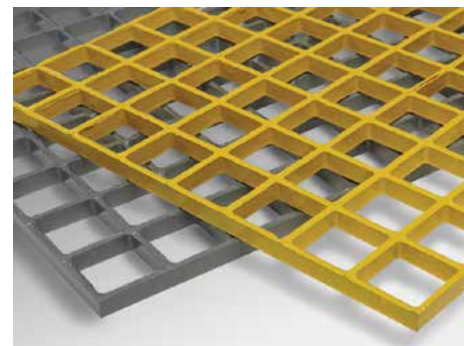

### Multigrid® Grating

A 1/2" deep square mesh screen/grating with 3/16" thick bars spaced 2" on center. This product, with 82% open area, is designed for uses such as screening, fencing, or machine guarding in caustic environments. Applications can include flooring and walkways if the grating is fully supported. Standard sheet size is 4' x 12' in yellow, green, or dark gray.

Weight per square foot: 1.0 lbs.

## FIBERPLATE FRP FLOOR PLATE

Manufactured by building layers of fiberglass reinforcement and resin to create a solid, corrosion-resistant composite that has bi-directional strength. The top of the plate includes an encapsulated, slip-resistant grit walking surface.

- Available in all molded grating resin systems
- Commonly installed over existing grating or concrete
- Easily cleaned by pressure washing
- Withstands most cleaning solutions



### FIBERPLATE® THICKNESS, WEIGHT, & SHEET SIZE

Thickness	Weight (psf)	Stock Sheets
1/8"*	1.3#	3' x 10', 4' x 8', 4' x 12'
1/4"	2.6#	3' x 10', 4' x 8', 4' x 12'
3/8"	3.9#	3' x 10', 4' x 8', 4' x 12'
1/2"	5.2#	3' x 10', 4' x 8', 4' x 12'
3/4"	7.8#	3' x 10', 4' x 8', 4' x 12'

\*1/8" thick plate designed for use as covering only; not recommended for load bearing service.  
Custom sizes are available

For additional technical information click link:  
[Fiberglass Grating Structural Components](#)

## FIBERGLASS GRATING EMBED ANGLE

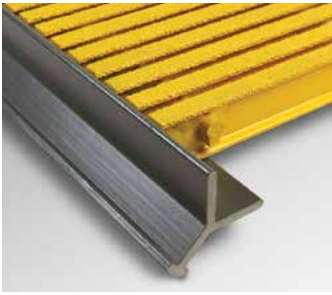

### FRP Concrete Curb Angle

Manufactured from corrosion resistant, gray vinyl ester, fire retardant resin, curb angles are pultruded with a built-in continuous anchor that securely locks the angle into the concrete pour.

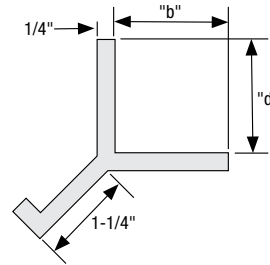

Grating Depth	"d" Dimension	"b" Dimension
1"	1"	1-1/2"
1-1/2"	1-1/2"	1-1/2"
2"	2"	1-1/2"



### EZ® Angle Embed Frame

The EZ Angle patented design eliminates the pullout factor common to un-ribbed fiberglass embed angles and anchor clips. EZ Angle frames are manufactured from slate-gray, vinyl ester, fire-retardant resin and precision designed for solid seating of 1", 1-1/2" and 2" deep gratings.

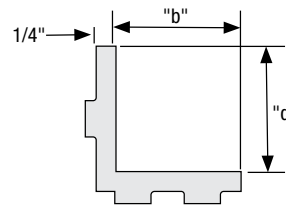

Grating Depth	"d" Dimension	"b" Dimension
1"	1"	1-1/2"
1-1/2"	1-1/2"	2"
2"	2"	1-1/2"
2-1/2"	2-1/2"	3"
3"	3"	2-1/2"

## DYNAFORM® FRP STRUCTURAL SHAPES & FABRICATION

Available for use in highly corrosive applications where stainless steel and other expensive components were once required. Produced in three resin systems, structural shapes are available in a wide range of efficient profiles.

- Beams
- Channels
- Angles
- Tubing
- Flat sheet
- Custom shapes



### Dynaform® Structural Fabrication

Services include CAD design, engineering certification, and full fabrication, of all our FRP product lines. Fiberglass structures can be shipped "knocked down", partially, or fully assembled.



### Dynarail® FRP Ladders

Exceeding OSHA requirements, ladders may be ordered with or without safety cage kits. Floor and wall mount kits facilitate easy installation.



### Dynarail® FRP Handrail

Fabricated with square posts and rails. Available in yellow or gray ISOFR. Easy to install. Toeplate is available for enhanced safety.



### Molded Grating Pedestals

Specially designed legs (pedestals) for square mesh molded grating provide sturdy support for elevated flooring.

**For additional technical information click link:**  
[Fiberglass Grating Structural Components](http://www.gratingpacific.com)



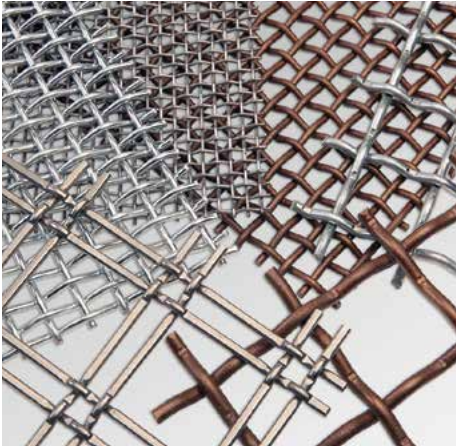
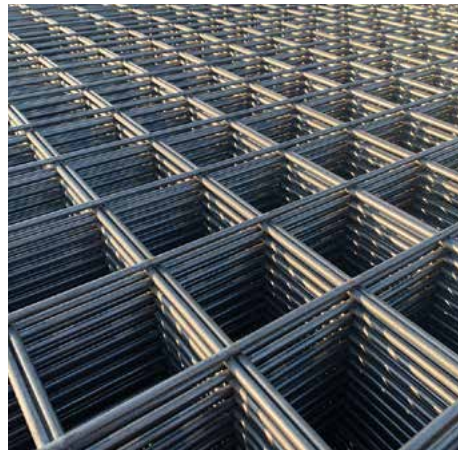
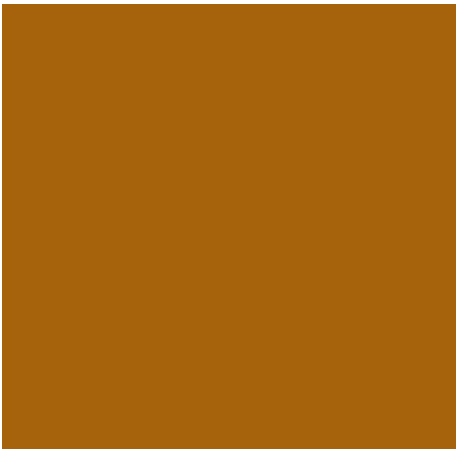



## WIRE MESH

Grating Pacific offers a wide variety of quality wire mesh and wire cloth products. Defined by their method of construction, woven or welded, wire mesh products are available in stock sheets or rolls. Wire mesh products are commonly manufactured from steel, aluminum, or stainless steel, but are also available in specialty alloys. Popular applications include:

- Industrial filtration
- Security Screening
- Handrail Infill Panels
- Fencing
- Design Interest

### Wire Mesh Products

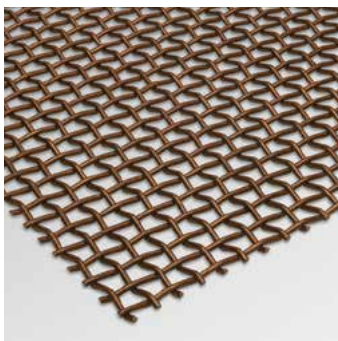

**Woven Wire Mesh**

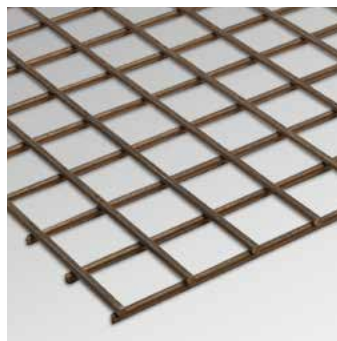

**Welded Wire Mesh**

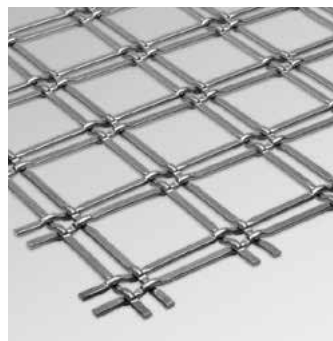

**Architectural Wire Products**

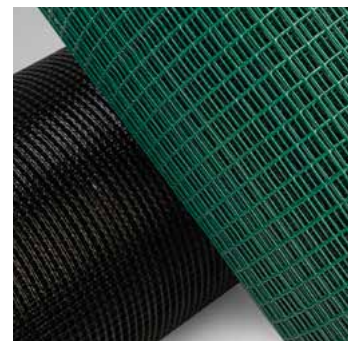

**Specialty Wire Mesh**

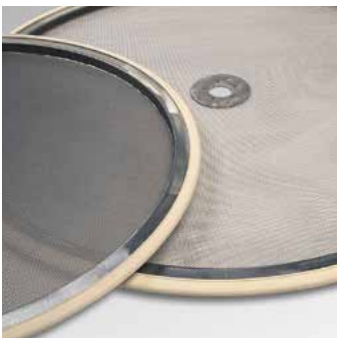

**Fabricated Wire Mesh Screens**



**Duetto™ Landscape Screens**

### Terminology

**CALENDARED WIRE CLOTH** – wire cloth that has been passed through heavy rollers to reduce the thickness of the material or flatten the wire intersections to produce a smooth surface.

**CLEAR OPENING** – the space between adjacent parallel wires.

**CRIMPS** – corrugations placed in the wire which allow the wires to be woven together. The placement and style of the crimps determine the location of the intersections and permit tight locking of the wires.

**CROSS WIRES** – used in welded wire construction, and running the width or short way of the material, cross wires are placed on top of line wires and welded into place.

**FILL WIRES** – wires running across the width or short way of the material as woven. (Also referred to as shute or cross wires.)

**GAUGE** – a measure of wire diameter commonly used by manufacturers. To avoid confusion between ferrous and non-ferrous gauge dimensions, always specify your desired wire diameter in decimal form.

**HARDWARE CLOTH** – square mesh cloth, galvanized after assembly and available in either woven or welded construction.

**LINE WIRES** – used in welded wire construction and running the length or long way of the material, line wires are placed in a pattern and are cross welded in place. Also known as long wires.

**MESH** – the number of openings in a lineal inch measured from the center of one wire to a point one inch distant.

**OPEN AREA** – the proportion of open space as a percentage of the total material area.

**SELVAGE** – a finished edge used to prevent fraying or unraveling of woven wire cloth.

**WARP WIRES** – wires running parallel to the length or long way of the material as woven.



## WELDED WIRE MESH

Economical and durable, welded wire mesh is manufactured on state-of-the-art, automated, grid welding equipment. Line and cross wires lay flat at each intersection and are resistance welded for maximum cross-sectional strength. Ideal for industrial use as well as architectural applications.

### Welded Wire Panels

- Wire diameters .035" to .375"
- Square mesh available in 1", 1-1/2", 2", 3", or 4" square mesh
- Rectangular mesh available in 1"x 2", 1"x 3", or 2" x 4"

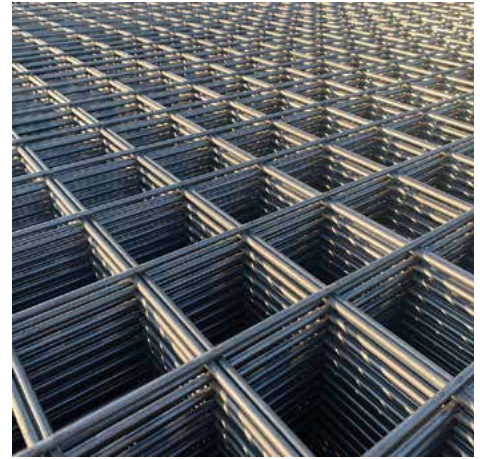
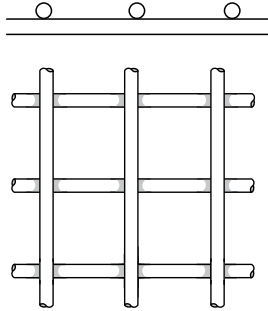

## WOVEN WIRE MESH

Grating Pacific has the capacity to weave a complete range of woven wire cloth to suit your most demanding applications. Our products range from simple square or rectangular patterns to complex products with compound crimp patterns and wire arrangements.

### Type PC - Plain Crimp

Square or rectangular pattern wire cloth using warp and fill wires of equal size. Warp wires pass over and under fill wires in an alternating pattern at adjacent intersections.

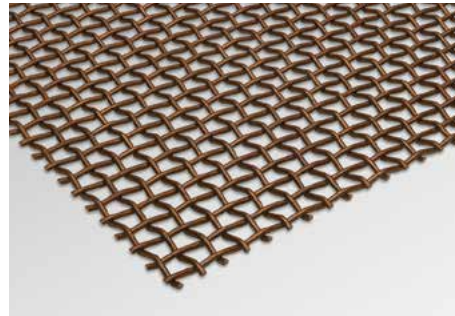

### Type IC - Intercrimp

Wire cloth manufactured with crimped warp wires filled at every other crimp with fill wires. The resulting cloth provides superior rigidity and greater stability.

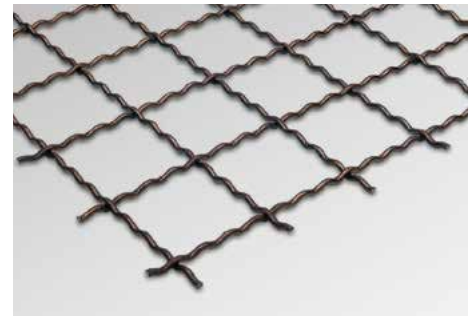
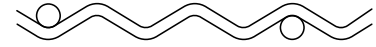

### Type LC - Lockcrimp

Versatile wire cloth manufactured to hold accurate openings. Each intersection is formed with straight sections of fill wires woven within straight sections of warp wires. Fill wires are woven in an alternating pattern, top and bottom.

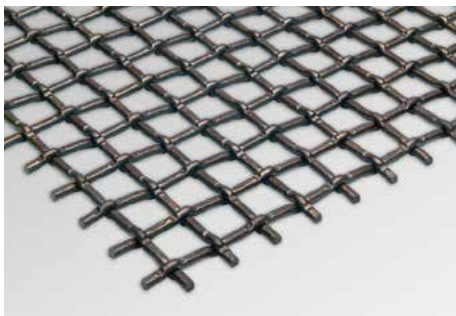

### Type FT - Flat Top Crimp

All crimping is offset to one side producing a wire cloth with all wire surfaces in a single plane on the top. This even surface allows for the smooth flow of materials over the top surface of the cloth.

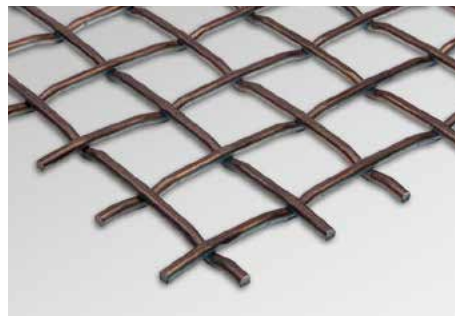
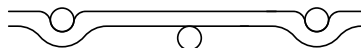

### Architectural Patterns

Customized crimp patterns with compound wire alignment using round or flat wires, yielding a dramatic appearance of the cloth.

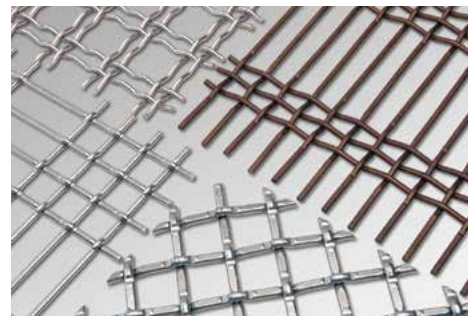

## Welded Wire Mesh

Welded products, with openings equal to or exceeding 1", are specified based on the center-to-center spacing of the wires.

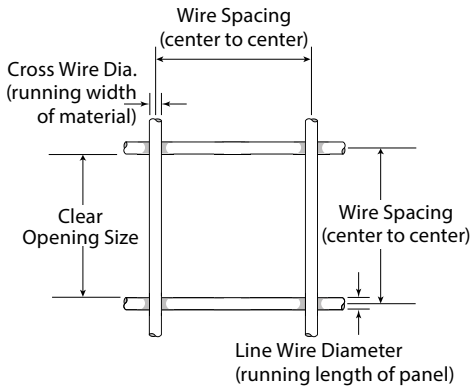

## Woven Wire Mesh

Woven products are specified as either Mesh, meaning center-to-center of wires, or Clear Opening which indicates the opening between the wires.

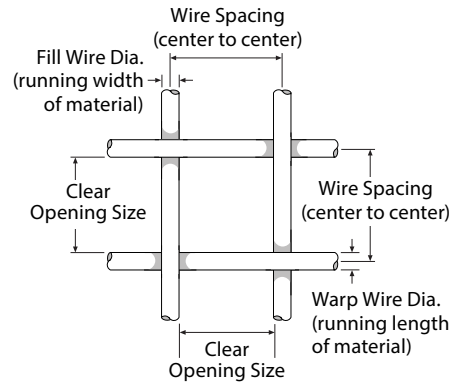

## Woven or Welded Wire Mesh (Spacing < 1")

Wire cloth with mesh sizes less than one inch can be specified by mesh count, center-to-center spacing, or clear opening size.

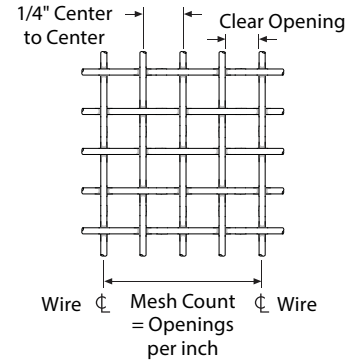

## Materials Available

**CARBON STEEL** - Plain low carbon steel typically ranging from C1006 to C1012 alloy, drawn from rod. Combines strength and weldability with economy.

### GALVANIZED BEFORE WEAVING / WELDING

Carbon steel coated with a light layer of zinc during the manufacturing process. Adequate corrosion resistance is provided for most indoor applications, but not recommended for outdoor installations.

### GALVANIZED AFTER WOVEN / WELDING

Carbon steel coated with a heavy layer of zinc after the manufacture of the mesh. Excellent for long term corrosion protection.

### HIGH CARBON STEEL

Abrasion resistant steel used for applications facing significant wear such as media filtering or sorting. Abrasion resistant steel can be difficult to weld, consider mechanical fastening to supporting structure.

**STAINLESS STEEL** - Commonly manufactured in 300 series alloys. Type 304 is most popular, but also available in types 309, 310, 316, 321, & 347. Series 400 alloys are also available on special order.

**ALUMINUM** - Lightweight and mildly resistant to corrosion, aluminum alloys are readily available. Alloy 1350 is most common and can be easily welded and anodized. Also available are alloys 5056 and 6061.

**NICKLE BASED ALLOYS** - Inconel 600, Monel 400, Nichrome V, and Hastalloy C276 offer specific characteristics desirable in specialized environments.

**Specialty Alloys** - Copper based alloys, bronze, brass, and titanium are also available for all woven products. Contact our sales engineers for assistance in selecting the proper specialty alloy for your application.

## How to Specify

### CONSTRUCTION

Woven or Welded (For woven products, identify crimp style).

### MATERIAL

Indicate material such as plain carbon steel, stainless steel, or other alloy.

### WIRE DIAMETER OR GAUGE

In decimal, thousands of one inch, or gauge.

### WIRE SPACING

Specify square, rectangular, or specialty configuration. Wire spacing center-to-center, clear opening, or mesh count.

### SIZES

Indicate sheet or roll width and length, or width and length of cut-to-size pieces.

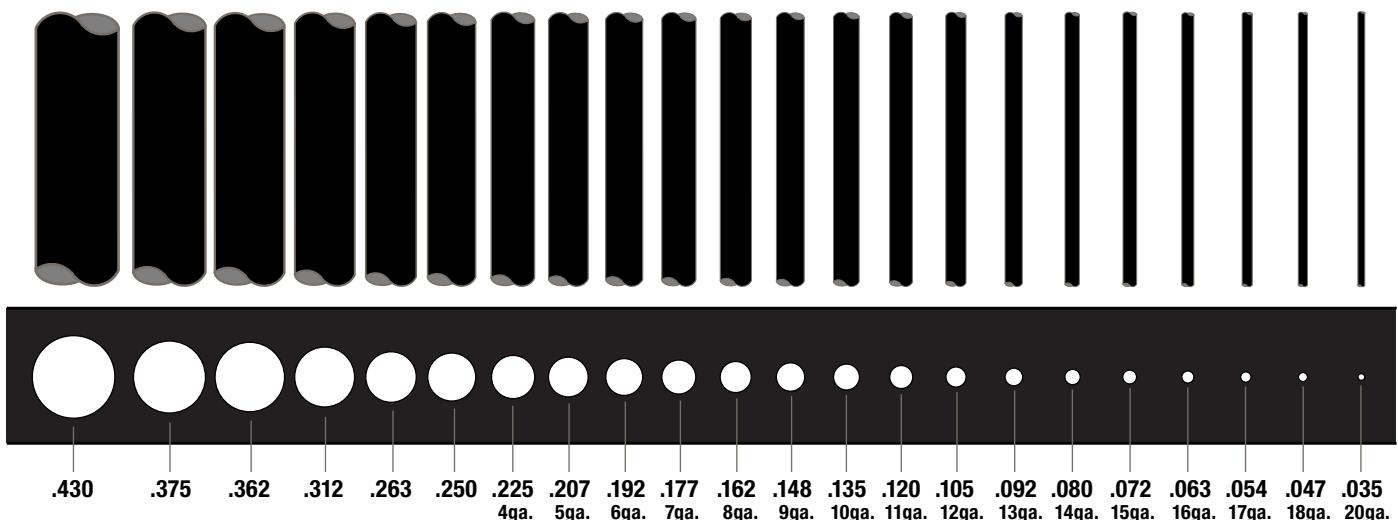



# WIRE MESH

## WELDED WIRE MESH SIZES & OPTIONS

Sizes indicated are our most popular products subject to manufacturing limitations. Additional spacings, wire diameters, and rectangular patterns are available on special order.

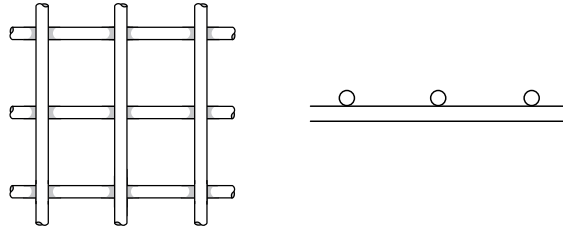

### 304 STAINLESS STEEL FLAT SHEETS

Alloys 309, 310, 316, 321, 347, and 400 series available on special order.

Mesh Spacing (center-to-center)	Wire Diameter	Weight per SF (pounds)	Open Area %	Sheet Sizes
1" Square	0.120	0.9	75.7%	Available from stock in 4' x 10' sheets.
2" Square	0.120	0.5	86.5%	

### CARBON WELDED STEEL FLAT SHEETS

Finish Options: Plain Steel, Pre-Galvanized (before welded), Hot Dip Galvanized (after welded), Galfan

Mesh Spacing (center-to-center)	Wire Diameter	Weight per SF (pounds)	Open Area %	Sheet Sizes
1" Square	0.120	0.9	75.7%	Available from stock in 4' x 10' sheets. Select sizes also available in 4' x 8', 5' x 10' or 6' x 10' sheets. Custom sizes available subject to minimum quantities.
1" Square	0.135	1.2	72.9%	
1-1/2" Square	0.135	0.8	80.8%	
2" Square	0.135	0.6	84.9%	
2" Square	0.192	1.2	78.9%	
2" Square	0.250	2.1	73.0%	
3" Square	0.192	0.8	84.6%	
3" Square	0.225	1.1	82.1%	
3" Square	0.250	1.4	80.3%	
4" Square	0.192	0.6	87.6%	
4" Square	0.225	0.9	85.6%	
4" Square	0.250	1.1	84.0%	
1" x 2" Rectangular	0.120	0.7	80.9%	
1" x 3" Rectangular	0.120	0.6	82.7%	
2" x 4" Rectangular	0.187	0.9	87.2%	

## WOVEN WIRE MESH SIZES & OPTIONS

Sizes indicated are our most popular products subject to manufacturing limitations. Additional spacings, wire diameters, and rectangular patterns are available on special order.

### CRIMP STYLES AVAILABLE:

PC - Plain Crimp

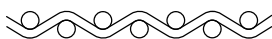

LC - Lock Crimp



IC - Intercrip



FT - Flat Top

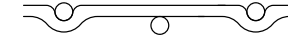

### CARBON STEEL FLAT SHEETS

Finish Options: Plain Steel, Pre-Galvanized (before woven), Hot Dip Galvanized (after woven), Galfan®

Clear Opening	Wire Diameter	Weight per SF (pounds)	Open Area %	Sheet Sizes
1/2" Square	0.120	1.49	65.0%	Available from stock in 4' x 10' sheets. Select sizes also available in 4' x 8', 5' x 10' or 6' x 10' sheets. Custom sizes available subject to minimum quantities.
3/4" Square	0.135	1.32	71.8%	
1" Square	0.120	0.82	79.7%	
1" Square	0.135	1.03	77.6%	
1" Square	0.192	1.98	70.4%	
1" Square	0.250	3.20	64.0%	
1-1/2" Square	0.135	0.71	84.2%	
1-1/2" Square	0.192	1.39	78.6%	
1-1/2" Square	0.250	2.29	73.5%	
1-3/4" Square	0.250	2.00	76.6%	
2" Square	0.135	0.55	87.8%	
2" Square	0.192	1.08	83.2%	
2" Square	0.250	1.78	79.0%	
3" Square	0.192	0.74	88.3%	
3" Square	0.250	1.23	85.2%	
3-3/4" Square	0.250	1.00	87.9%	
4" Mesh	0.375	2.00	83.6%	

## WOVEN WIRE MESH SIZES & OPTIONS (CONTINUED...)

Sizes indicated are our most popular products subject to manufacturing limitations. Additional spacings, wire diameters, and rectangular patterns are available on special order.

### 304 STAINLESS STEEL FLAT SHEETS

Alloys 309, 310, 316, 321, 347, and 400 series available on special order.

Clear Opening	Wire Diameter	Weight per SF (pounds)	Open Area %	Sheet Sizes
1/2" Square	0.120	1.53	65.0%	Available from stock in 4' x 10' sheets. Custom sizes available subject to minimum quantities.
1" Square	0.120	0.85	79.7%	
1-1/2" Square	0.120	0.59	85.7%	
2" Square	0.120	0.45	89.0%	
2" Square	0.135	0.56	87.8%	
2" Square	0.192	1.11	83.2%	
2" Square	0.250	1.83	79.0%	
3" Square	0.192	0.76	88.3%	
4" Square	0.250	0.97	88.6%	

### 1350 ALUMINUM FLAT SHEETS

Alloys 5056 and 6061 available on special order.

Clear Opening	Wire Diameter	Weight per SF (pounds)	Open Area %	Sheet Sizes
2" Square	0.250	0.62	79.0%	4' x 10'

## WIRE MESH ROLLS - SIZES & OPTIONS

Sizes indicated are our most popular products subject to manufacturing limitations. Additional spacings, wire diameters, and rectangular patterns are available on special order.



### Fine Mesh Wire Cloth

Popular for filtering and sifting applications, these products are available in mesh sizes from 10 to 500 mesh per inch.



### Insect Screen

Available in a wide range of material, typical wire diameter is .011" spaced in a 18 x16 or 18 x 14 mesh.

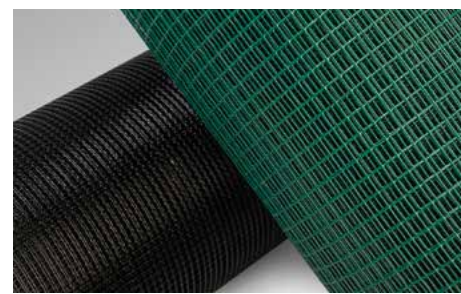

### PVC Coated Hardware Cloth

Corrosion resistant and popular for rodent control applications, this wire cloth is available in 2 mesh or 4 mesh openings.

### CARBON STEEL WOVEN WIRE - SQUARE MESH

Finish Options: Plain Steel, Pre-Galvanized (before woven)

Mesh (center-to-center)	Wire Diameter	Clear Opening	% of Open Area	Lbs. per 100 Sq Ft
2	0.063	0.437	75.5%	50.8
2	0.080	0.420	69.4%	81.9
3	0.047	0.286	73.1%	42.4
4	0.025	0.225	80.6%	16.0
4	0.047	0.203	65.3%	56.6
4	0.063	0.187	55.2%	101.6
6	0.028	0.139	68.8%	30.1
8	0.025	0.100	63.7%	32.0
8	0.035	0.090	51.4%	62.7
10	0.023	0.077	59.0%	33.9
10	0.035	0.065	41.9%	78.4

### 1350 Aluminum Rolls

Alloys 5056 and 6061 available on special order.

Mesh (center-to-center)	Wire Diameter	Clear Opening	% of Open Area	Lbs. per 100 Sq Ft
2	0.063	0.437	75.5%	17.6
4	0.047	0.203	65.3%	19.6
4	0.063	0.187	55.2%	35.2
8	0.028	0.097	59.9%	13.9

### GALVANIZED WELDED/WOVEN HARDWARE CLOTH - SQUARE MESH

Finish Options: PVC Coated 2 and 4 Mesh only

Mesh (center-to-center)	Wire Diameter	Clear Opening	% of Open Area	Lbs. per 100 Sq Ft
2	0.041	0.459	83.6%	21.5
2	0.063	0.437	75.5%	50.8
3	0.032	0.301	81.2%	19.7
4	0.025	0.225	80.6%	16.0
4	0.032	0.218	75.6%	26.2
4	0.047	0.203	65.3%	56.6
8	0.017	0.108	74.4%	14.8

### 304 STAINLESS STEEL WELDED WIRE - SQUARE MESH

Alloys: T304 or T316

Mesh (center-to-center)	Wire Diameter	Clear Opening	% of Open Area	Lbs. per 100 Sq Ft
2	0.047	0.453	81.4%	29.1
2	0.063	0.437	75.5%	52.3
3	0.047	0.286	73.1%	43.6
4	0.022	0.228	82.8%	12.7
4	0.028	0.222	78.4%	20.6
4	0.032	0.218	75.6%	27.0
4	0.047	0.203	65.3%	58.2



# WIRE MESH

## WIRE MESH ROLLS - SIZES & OPTIONS (CONTINUED...)

Sizes indicated are our most popular products subject to manufacturing limitations. Additional spacings, wire diameters, and rectangular patterns are available on special order.

### 304 STAINLESS STEEL WOVEN WIRE - SQUARE MESH

Alloys 309, 310, 316, 321, 347, and 400 series available on special order.

Mesh (center-to-center)	Wire Diameter	Clear Opening	% of Open Area	Lbs. per 100 Sq Ft
2	0.120	0.380	56.3%	189.6
2	0.080	0.420	69.4%	84.3
3	0.063	0.270	64.9%	78.4
3	0.080	0.253	56.8%	126.4
4	0.047	0.203	65.3%	58.2
4	0.063	0.187	55.2%	104.5
4	0.080	0.170	45.3%	168.5
5	0.041	0.159	62.7%	55.3
6	0.028	0.139	68.8%	31.0
6	0.035	0.132	62.0%	48.4
7	0.028	0.115	64.3%	36.1
7	0.035	0.108	56.6%	56.4
8	0.028	0.097	59.9%	41.3
8	0.032	0.093	55.0%	53.9
8	0.035	0.090	51.4%	64.5
8	0.047	0.078	38.5%	116.3
9	0.023	0.088	62.6%	31.3
10	0.020	0.080	63.7%	26.3
10	0.025	0.075	55.9%	41.1
10	0.035	0.065	41.9%	80.6
11	0.018	0.073	64.1%	23.5
12	0.018	0.065	61.2%	25.6
12	0.028	0.055	43.8%	61.9
14	0.009	0.062	76.3%	7.5
14	0.017	0.054	57.8%	26.6
14	0.020	0.051	51.6%	36.9
14	0.025	0.046	42.0%	57.6
16	0.009	0.054	73.1%	8.5
16	0.018	0.045	50.5%	34.1
18	0.009	0.047	70.1%	9.6
18	0.017	0.039	48.0%	34.2
20	0.009	0.041	67.1%	10.7
20	0.016	0.034	46.1%	33.7
24	0.008	0.034	67.1%	8.9
26	0.011	0.027	50.8%	20.7

### 304 STAINLESS STEEL WOVEN WIRE - SQUARE MESH

Alloys 309, 310, 316, 321, 347, and 400 series available on special order.

Mesh (center-to-center)	Wire Diameter	Clear Opening	% of Open Area	Lbs. per 100 Sq Ft
28	0.010	0.026	51.7%	18.4
30	0.013	0.020	37.1%	33.4
32	0.0065	0.025	62.6%	8.9
40	0.010	0.015	35.9%	26.3
50	0.009	0.011	30.2%	26.7
60	0.0075	0.009	30.2%	22.2
70	0.0065	0.008	29.6%	19.5
80	0.0055	0.007	31.3%	15.9
100	0.0045	0.006	30.2%	13.3
105	0.0035	0.006	40.0%	8.5
120	0.0026	0.006	47.3%	5.3
145	0.0022	0.005	46.4%	4.6
150	0.0026	0.004	37.2%	6.7
180	0.0018	0.004	45.7%	3.8
250	0.0016	0.002	36.0%	4.2
325	0.0014	0.002	29.7%	4.2

### PRE-GALVANIZED WELDED WIRE FABRIC ROLL STOCK - RECTANGULAR MESH

Finish Options: Pre-Galvanized or PVC Coated

Mesh (center-to-center)	Wire Diameter	Clear Opening	% of Open Area	Lbs. per 100 Sq Ft
1" x 1"	16 ga.	0.935	86.4%	27.1
1" x 1"	14 ga.	0.917	82.8%	44.2
2" x 2"	16 ga.	1.935	92.6%	54.2
2" x 2"	14 ga.	1.917	90.6%	88.3
2" x 2"	12.5 ga.	1.898	88.5%	133.4
1" x 1/2"	16 ga.	.935 x .435	81.3%	40.6
2" x 1"	14 ga.	1.92 x .92	87.9%	33.10
4" x 2"	16 ga.	3.94 x 1.94	95.2%	10.15
4" x 2"	14 ga.	3.92 x 1.92	93.9%	16.56
4" x 2"	12.5 ga.	3.9 x 1.90	92.5%	25.10

## DUETTO™ LANDSCAPE SCREENS

Duetto wire mesh plant screens combine form, function, and strength. Twin layers of woven or welded wire mesh are framed with rigid steel framing to support plant growth and maintenance. Durable, flexible, and easily installed.



### Duetto™ Screens

Sturdy, attractive, and economical panels. Offered as wall-mounted facades or as a free-standing fence system with optional gates.



### Duetto™ Trellises

A simple, elegant method of making architectural structures more attractive. Appealing as either vertical or horizontal elements. Custom designed structural options are also available.



### Duetto™ Rock Boxes

Robust fabricated enclosures that incorporate inorganic materials or rocks as the prevailing visual element. Virtually maintenance-free and popular for landscape projects.



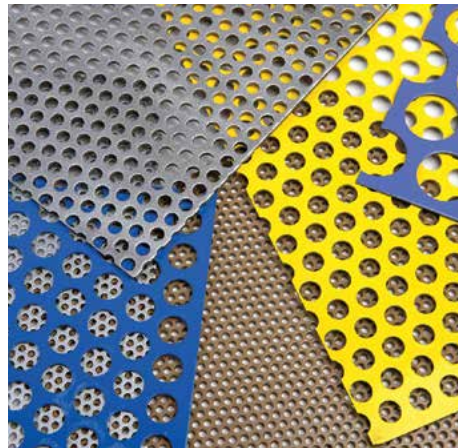

# PERFORATED METAL





## PERFORATED METAL

Perforated metal is manufactured by mechanically stamping or punching sheets of steel, aluminum, stainless steel, or specialty alloys to create patterns of round or square holes, slots, and other ornamental shapes. Popular for its functional and aesthetic appeal, common applications of perforated metal include:

- Industrial filtration
- Screens & sorting
- Architectural accents
- Ventilation covers
- Machine guards
- Signage backdrop

### Products

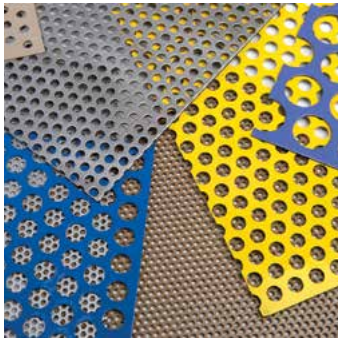

Round Hole

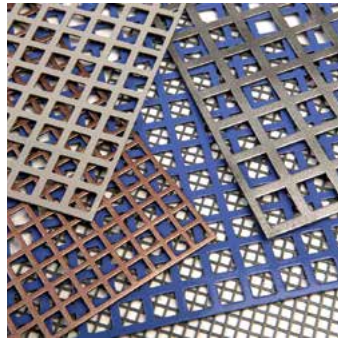

Square Hole

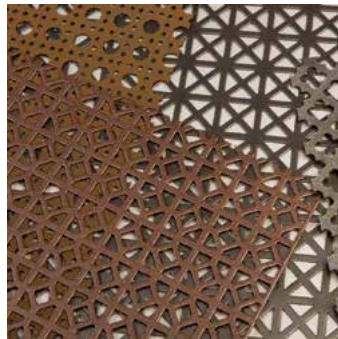

Slotted and Ornamental



Custom and Specialty

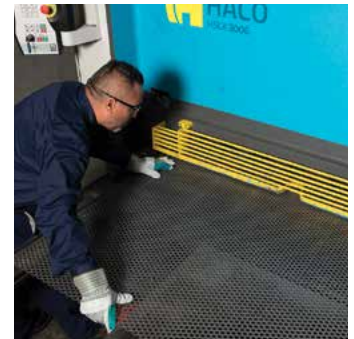

Custom Fabrication & Finishes

## Round Hole Patterns

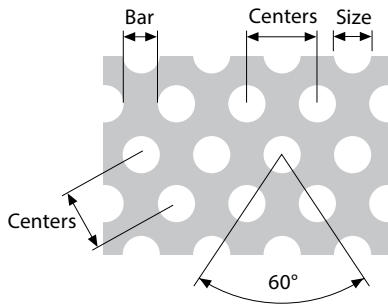

STANDARD ROUND PERFORATIONS  
60° STAGGERED

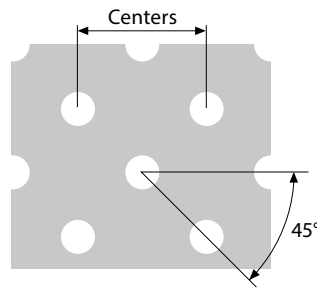

OPTIONAL ROUND PERFORATIONS  
45° STAGGERED

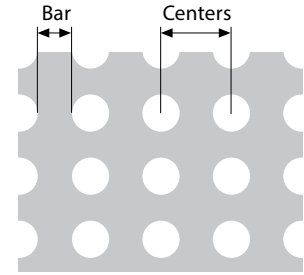

STRAIGHT LINE ROUND  
PERFORATIONS

## Square Hole Patterns

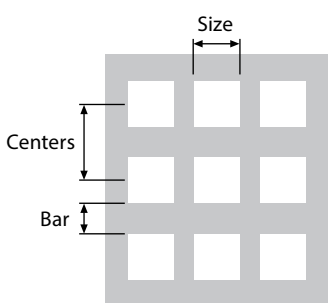

STRAIGHT LINE SQUARE  
PERFORATIONS

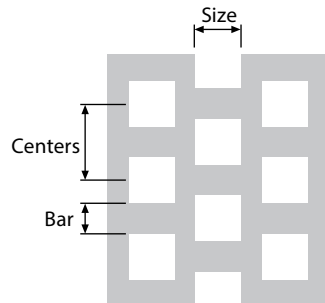

SQUARE PERFORATIONS  
STAGGERED

## Pattern Alignment

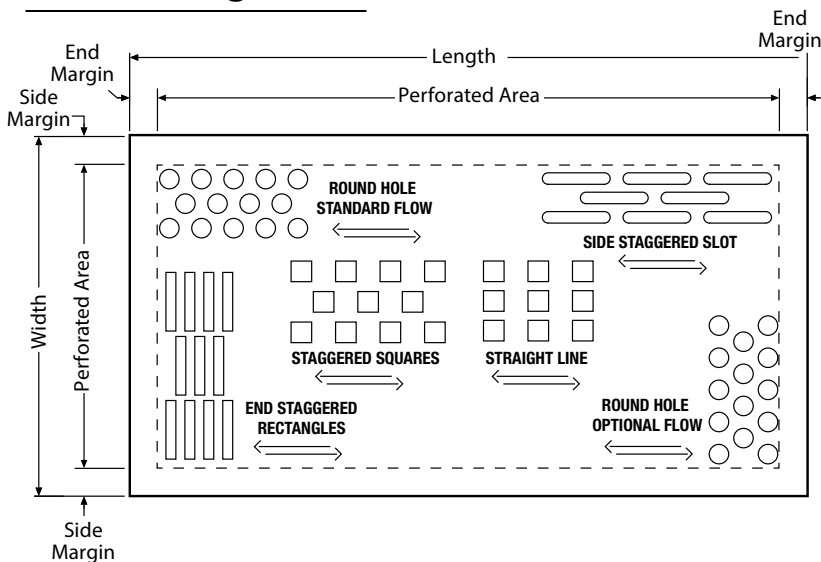

## How to Specify Perforated Metal

### 1. USE AND APPLICATION

Specify for indoor or outdoor application and advise the function to be served such as architectural interest, screening, filtration, or other.

### 2. PERFORATION TYPE AND PATTERN

Specify the geometry and size of the hole or slot, the center-to-center dimension of the perforations, and whether the perforations are to be staggered or in-line.

### 3. PERCENTAGE OF OPEN AREA

If critical, specify the percentage of open area desired.

### 4. MATERIAL REQUIREMENT

Choose between carbon steel, pre-galvanized steel, stainless steel, aluminum, or specialty alloys. Include details about gauge of material (thickness).

### 5. MARGINS

Specify if margins are required and whether they are needed at specific sides only, or around the entire perimeter.

### 6. PATTERN FLOW

Choose between standard or optional flow.

### 7. DIMENSIONAL REQUIREMENTS

Specify sizes and quantity of sheets required.

### 8. FABRICATION

Specify if framing, edging, or other requirements are necessary.

### 9. FINISH

Specify type of finish desired.

## End Margins

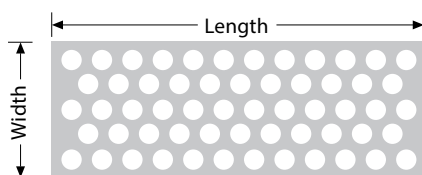

FINISHED END MARGIN

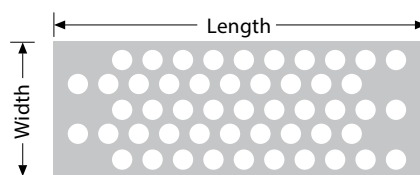

UNFINISHED END MARGIN

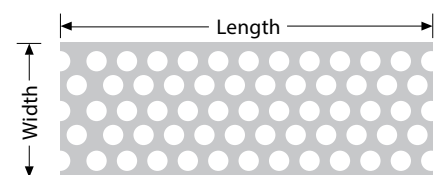

BLANK MARGIN



# PERFORATED METAL

## Custom Perforated Metal

Special margins, irregular configurations, upset punching, and open area are just a few options for custom perforated products. Secondary fabrication such as shearing, coping, forming, and finishing are also readily available.

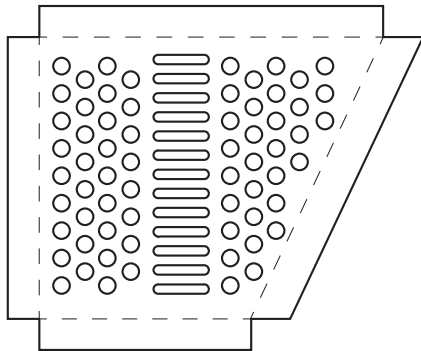

## Fabrication

Our fabrication teams are highly trained and ready to shear, form, roll, frame, or customize any perforated metal panel order. These services can be provided to a single sheet, multiple panels, or high volume OEM requirements.



## Finishes

Perforated metal is available in a variety of metals: carbon steel, stainless steel, aluminum, and specialty alloys. All products are lightly oiled during manufacture and stocked mill finish, without cleaning. If finish coatings will be applied, the metal should be cleaned prior to coating.

Carbon steel perforated metal can easily be painted or galvanized to enhance corrosion resistance. Aluminum products can be anodized, or epoxy coated. Stainless steel products can be electroplated to provide a bright finish or abrasive blasted to provide a uniform matte finish. Other specialty alloys have finish options related to the type of alloy.



## PERFORATED METAL SIZES & OPTIONS

ROUND HOLES STAGGERED PATTERN			
Hole	Centers	Gauge/Plate Thickness	Open Area
<b>Carbon Steel</b>			
.020" RD	.045" Stag	26	18%
1/32" RD	1/16" Stag	22	23%
3/64" RD	5/64" Stag	24	33%
3/64" RD	3/32" Stag	22 thru 18	23%
1/16" RD	3/32" Stag	22 thru 16	40%
1/16" RD	7/64" Stag	20 thru 16	30%
1/16" RD	1/8" Stag	26 thru 16	23%
5/64" RD	1/8" Stag	22 thru 14	35%
3/32" RD	5/32" Stag	24 thru 14	33%
3/32" RD	3/16" Stag	24	23%
.117 RD	5/32" Stag	18	51%
1/8" RD	3/16" Stag	24 thru 11	40%
1/8" RD	7/32" Stag	14 thru 12	30%
1/8" RD	1/4" Stag	14, 13	23%
9/64" RD	3/16" Stag	18	51%
5/32" RD	3/16" Stag	22 thru 16	63%
5/32" RD	1/4" Stag	20 thru 10	35%
3/16" RD	7/32" Stag	22 thru 16	67%
3/16" RD	1/4" Stag	24 thru 12	51%
3/16" RD	5/16" Stag	10, 3/16"	33%
3/16" RD	3/8" Stag	14 thru 10	23%

ROUND HOLES STAGGERED PATTERN			
Hole	Centers	Gauge/Plate Thickness	Open Area
<b>Carbon Steel</b>			
1/4" RD	5/16" Stag	20 thru 16	58%
1/4" RD	3/8" Stag	26 thru 1/4"	40%
17/64" RD	5/16" Stag	20	66%
5/16" RD	7/16" Stag	20 thru 1/4"	46%
3/8" RD	9/16" Stag	20 thru 1/4"	40%
1/2" RD	11/16" Stag	20 thru 1/4"	48%
1/2" RD	3/4" Stag	16	40%
5/8" RD	7/8" Stag	10 thru 1/4"	46%
3/4" RD	1" Stag	16 thru 1/4"	51%
1" RD	1-3/8" Stag	10 thru 1/4"	48%
1-1/4" RD	1-5/8" Stag	1/4"	54%
1-1/2" RD	2" Stag	1/4"	51%
2" RD	2-1/2" Stag	1/4"	58%
2-1/2" RD	3" Stag	3/16"	63%
3" RD	3-1/2" Stag	3/16"	67%
4" RD	4-1/2" Stag	10	72%
<b>G-90 Pre-Galvanized Steel</b>			
5/64" RD	1/8" Stag	18	35%
3/32" RD	5/32" Stag	22 thru 18	33%
3/32" RD	3/16" Stag	20	23%
7/64" RD	3/16" Stag	16	31%

ROUND HOLES STAGGERED PATTERN			
Hole	Centers	Gauge/Plate Thickness	Open Area
<b>G-90 Pre-Galvanized Steel</b>			
1/8" RD	3/16" Stag	20 thru 16	40%
3/16" RD	7/32" Stag	18	67%
3/16" RD	1/4" Stag	20 thru 16	51%
3/16" RD	3/8" Stag	20	23%
1/4" RD	5/16" Stag	20	58%
5/16" RD	7/16" Stag	16	46%
3/8" RD	1/2" Stag	16	51%
<b>Stainless Steel - Type 304</b>			
.020" RD	.045" Stag	30	18%
1/32" RD	1/16" Stag	26	23%
3/64" RD	3/32" Stag	24	23%
.050" RD	5/64" Stag	26, 24	37%
1/16" RD	3/32" Stag	22, 20	40%
1/16" RD	7/64" Stag	26, 22	30%
1/16" RD	1/8" Stag	26 thru 18	23%
5/64" RD	1/8" Stag	22, 20	35%
3/32" RD	5/32" Stag	22 thru 14	33%
.117 RD	5/32" Stag	22	51%
1/8" RD	3/16" Stag	26 thru 11	40%
1/8" RD	7/32" Stag	14, 11	30%
9/64" RD	3/16" Stag	18	51%

## PERFORATED METAL SIZES & OPTIONS

### ROUND HOLES STAGGERED PATTERN

Hole	Centers	Gauge/Plate Thickness	Open Area
<b>Stainless Steel - Type 304</b>			
5/32" RD	3/16" Stag	20 thru 16	63%
3/16" RD	1/4" Stag	24 thru 14	51%
3/16" RD	5/16" Stag	11	33%
1/4" RD	5/16" Stag	22 thru 16	58%
1/4" RD	3/8" Stag	20 thru 3/16"	40%
5/16" RD	7/16" Stag	16	46%
3/8" RD	9/16" Stag	16, 11	40%
1/2" RD	11/16" Stag	20 thru 3/16"	48%
3/4" RD	1" Stag	16, 11	51%
<b>Stainless Steel - Type 316</b>			
3/32" RD	5/32" Stag	14	33%
1/8" RD	3/16" Stag	16	40%
5/32" RD	3/16" Stag	16	63%
3/16" RD	1/4" Stag	22 thru 16	51%
<b>Aluminum - Alloy 3003-H14</b>			
3/64" RD	5/64" Stag	20	33%
.050" RD	5/64" Stag	20, 18	37%
1/16" RD	1/8" Stag	22 thru 14	23%
5/64" RD	1/8" Stag	16, 14	35%
3/32" RD	5/32" Stag	22 thru 14	33%
1/8" RD	3/16" Stag	24 thru .125	40%
1/8" RD	21/64" Stag	.090	13%
5/32" RD	3/16" Stag	20 thru 14	63%
3/16" RD	7/32" Stag	16	67%
3/16" RD	1/4" Stag	20 thru .125	51%
3/16" RD	3/8" Stag	18, 14	23%
1/4" RD	5/16" Stag	16, 20	58%
1/4" RD	3/8" Stag	20 thru .125	40%
1/4" RD	1/2" Stag	16	23%
3/8" RD	9/16" Stag	14	40%
1/2" RD	11/16" Stag	14, .125	48%
3/4" RD	1" Stag	16, 11	51%
<b>Aluminum - Alloy 5052-H32</b>			
1/16" RD	1/8" Stag	20, 16	23%
1/16" RD	7/64" Stag	16	30%
3/32" RD	3/16" Stag	.080	23%
1/8" RD	3/16" Stag	16	40%
1/8" RD	21/64" Stag	14	13%
3/16" RD	1/4" Stag	14	51%
<b>Aluminum - Alloy 6061-T6</b>			
1/8" RD	3/16" Stag	20 thru 14	40%
1/4" RD	3/8" Stag	14	40%
<b>Aluminum - Alloy 7075-0</b>			
3/32" RD	1/4" Stag	16 thru .125	13%
5/32" RD	3/8" Stag	.090	16%
<b>Brass</b>			
.020" RD	.045" Stag	26	18%
.033" RD	.079" Stag	26	16%
3/32" RD	5/32" Stag	22, 20	33%

### ROUND HOLES STRAIGHT LINE PATTERN

Hole	Centers	Gauge/Plate Thickness	Open Area
<b>Carbon Steel</b>			
.027" RD	.050" Strght	26	23%
.050" RD	.066" Strght	24	45%
1/4" RD	3/8" Strght	16	35%
1/4" RD	1/2" Strght	18, 16	20%
1/4" RD	1" Strght	3/16"	5%
<b>G-90 Pre-Galvanized Steel</b>			
.037" RD	.055" Strght	26	36%
<b>Stainless Steel - Type 304</b>			
.033" RD	.055" Strght	26	28%
.045" RD	.066" Strght	24	37%
.050" RD	.066" Strght	26	45%
1/16" RD	7/16" Strght	26	2%
3/16" RD	3/8" Strght	18	20%
<b>Aluminum - Alloy 3003-H14</b>			
.033" RD	.055" Strght	20	28%
.040" RD	.066" Strght	20	29%
.050" RD	.066" Strght	20, 18	45%
1/2" RD	5/8" Strght	14	50%
<b>Brass</b>			
.045" RD	.066" Strght	24	37%
.050" RD	.083" Strght	24	29%

### SQUARE HOLES STRAIGHT LINE PATTERN

Hole	Centers	Gauge/Plate Thickness	Open Area
<b>Carbon Steel</b>			
.200 SQR	1/4" Strght	22, 20	64%
1/4" SQR	5/16" Strght	20	64%
3/8" SQR	1/2" Strght	22, 16	56%
1/2" SQR	5/8" Strght	16	64%
1/2" SQR	11/16" Strght	18	53%
3/4" SQR	1" Strght	16	56%
<b>Stainless Steel - Type 304</b>			
.200 SQR	1/4" Strght	22	64%
<b>Aluminum - Alloy 3003-H4</b>			
.200 SQR	1/4" Strght	20	64%

### HEX HOLES STAGGERED PATTERN

Hole	Centers	Gauge/Plate Thickness	Open Area
<b>Carbon Steel</b>			
1/4" HEX	9/32" Stag	22	79%
<b>G-90 Pre-Galvanized Steel</b>			
1/4" HEX	9/32" Stag	22	79%
<b>Aluminum - Alloy 3003-H14</b>			
1/4" HEX	9/32" Stag	20	79%

### ORNAMENTAL PATTERNS

Designation	Pattern	Gauge	Open Area
<b>Carbon Steel</b>			
Cloverleaf	Staggered	22	50%
Grecian	Straight Line	22	35%
Marietta	Straight Line	22	45%
Moire	Staggered	22	41%
Octagon	Straight Line	22	35%
<b>Aluminum - Alloy 3003-H14</b>			
Grecian	Straight Line	20	35%
Windsor	Straight Line	20	45%

### OBLONG HOLES STAGGERED PATTERN

Designation	Pattern	Gauge/Plate Thickness	Open Area
<b>Carbon Steel</b>			
1/8" x 3/4" OBL	7/8" Stag	22	41%
1/2" x 1" OBL	11/16" Stag	3/8"	65%

For additional information click link:  
[Perforated Metal Products](#)



## ROUND HOLE PATTERNS

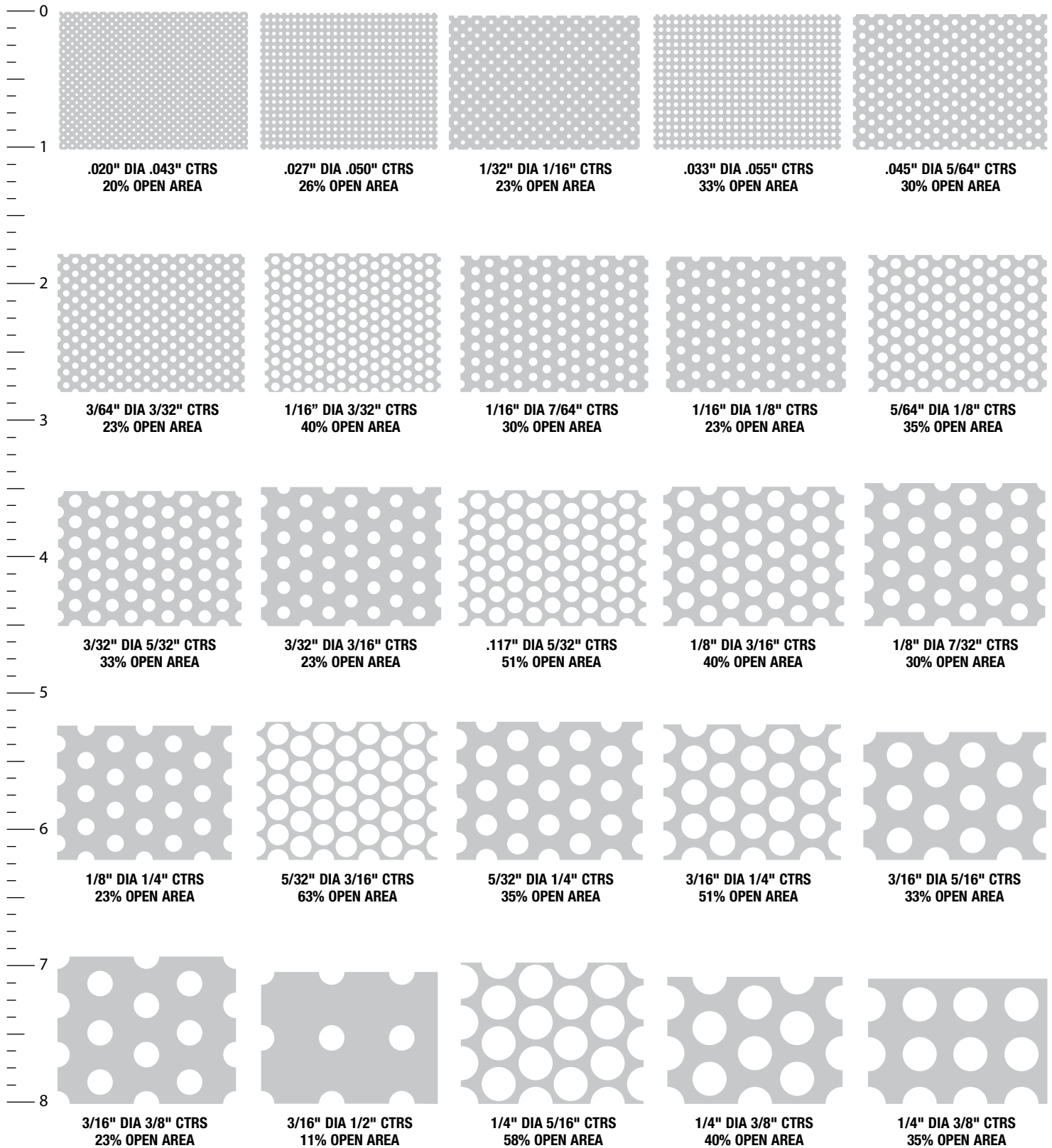

Use the embedded ruler to confirm print out is in actual size (print at actual size). Please use a physical ruler.

## ROUND HOLE PATTERNS

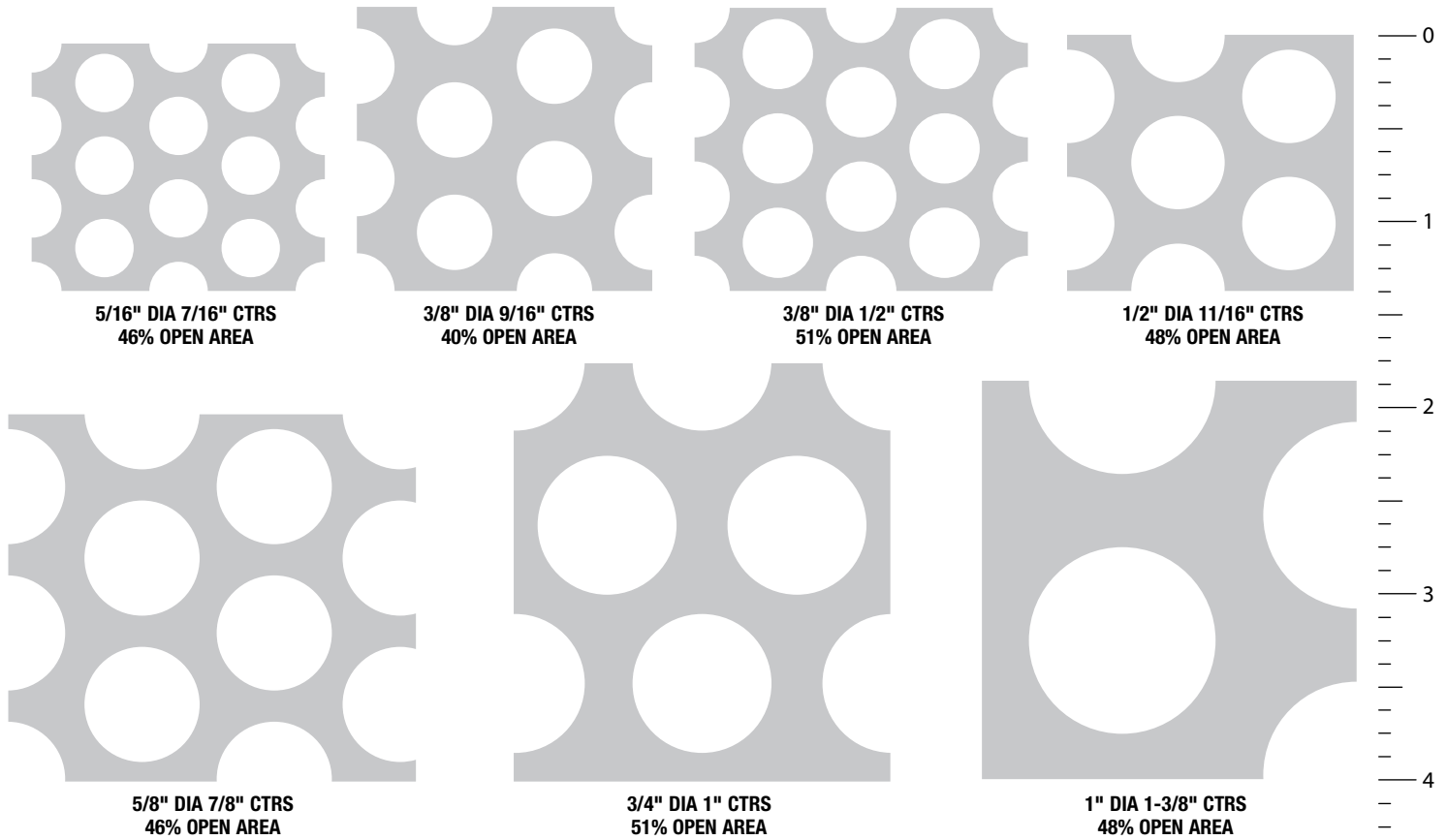

## SQUARE HOLE PATTERNS

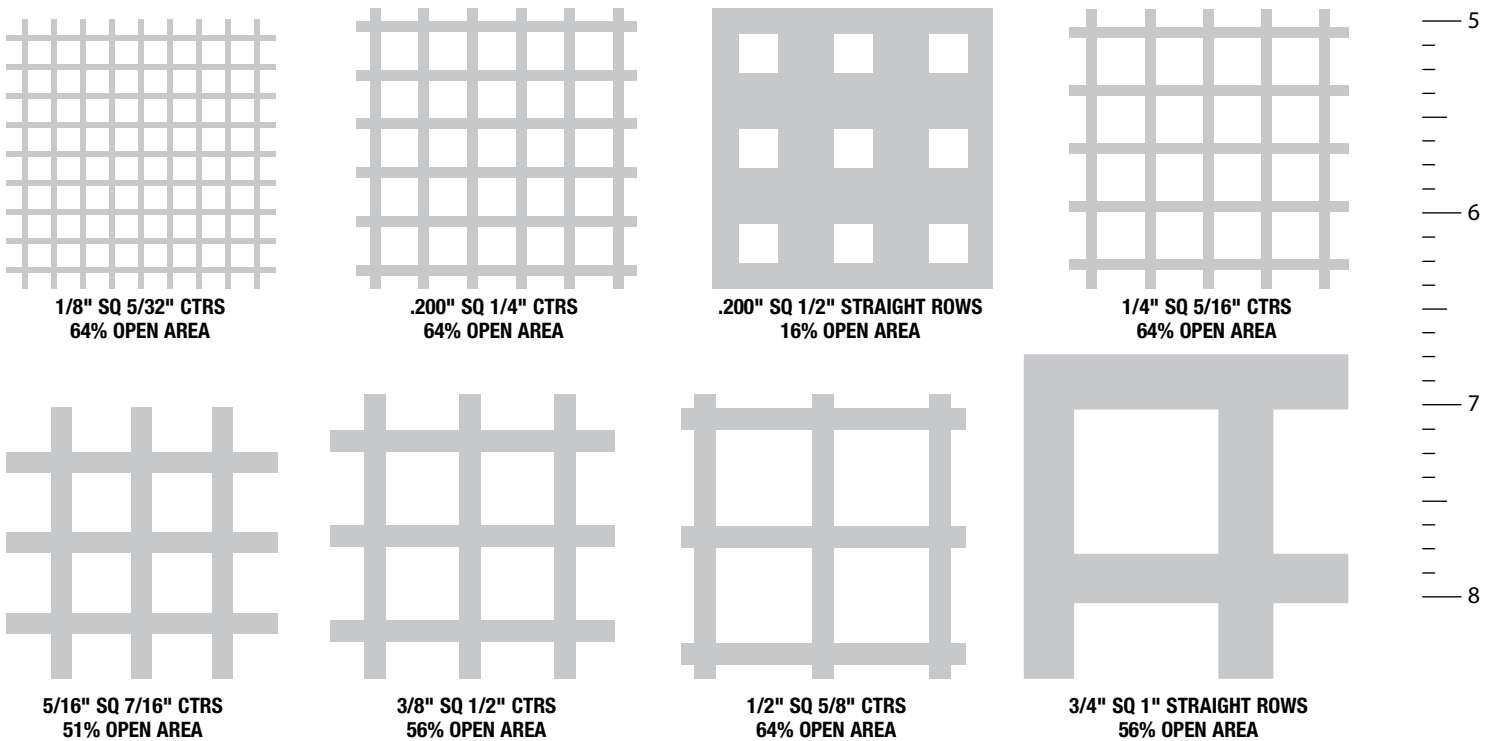

Use the embedded ruler to confirm print out is in actual size (print at actual size). Please use a physical ruler.



## SLOTTED & ORNAMENTAL PATTERNS

### Slotted Hole Perforated Patterns

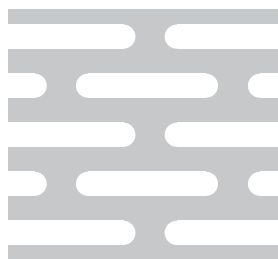

SIDE STAGGERED SLOTS  
(OR RECTANGULAR)

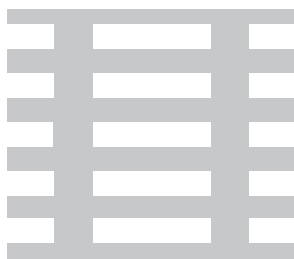

STRAIGHT LINE RECTANGULAR  
(OR SLOTS)

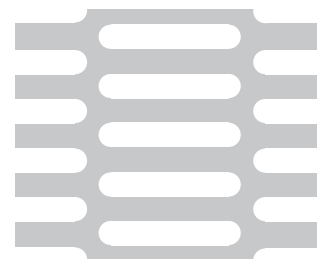

END STAGGERED SLOTS  
(OR RECTANGULAR)

### Ornamental Perforated Patterns\*

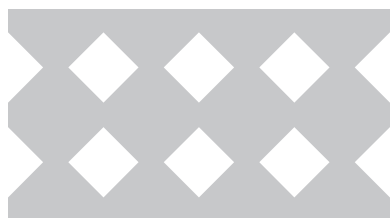

DIAMOND CANE 19% OPEN



MARIETTA 45% OPEN



GRECIAN 35% OPEN

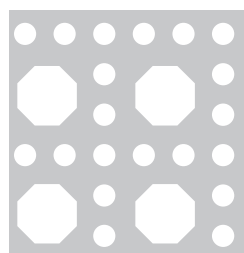

STANDARD OCTAGON  
35% OPEN

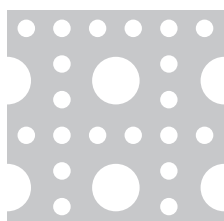

ROUND CANE  
38% OPEN

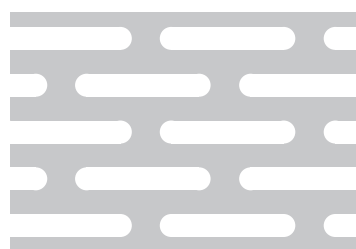

MOIRE  
41% OPEN 1/8" X 3/4"



FULL CLOVERLEAF  
50% OPEN



HEXAGON 1/4"  
79% OPEN



MAX-FLOW 68% OPEN SLOTS 1/4" X 1-1/2", IN ROWS ACROSS WIDTH OF SHEET. VERTICAL BARS 3/32" WIDE, WITH EVERY THIRD BAR 3/16"

\*Ornamental perforated patterns are available in 22 gauge carbon steel only.

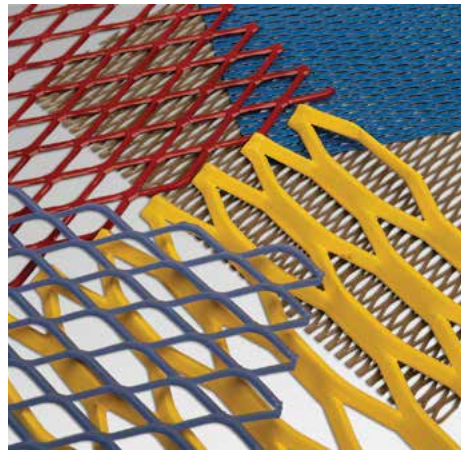
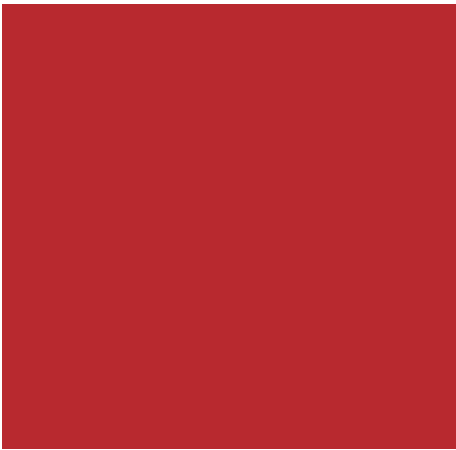

# EXPANDED METAL





## EXPANDED METAL

Manufactured by slitting and stretching metal sheets into an open diamond pattern, expanded metal is strong, rigid, and lightweight. Available in carbon steel, aluminum, or stainless steel, light duty expanded metal is available with a standard, slightly raised surface, or a flattened, smooth finish. Heavy gauge expanded metal grating is designed to serve pedestrian loads.

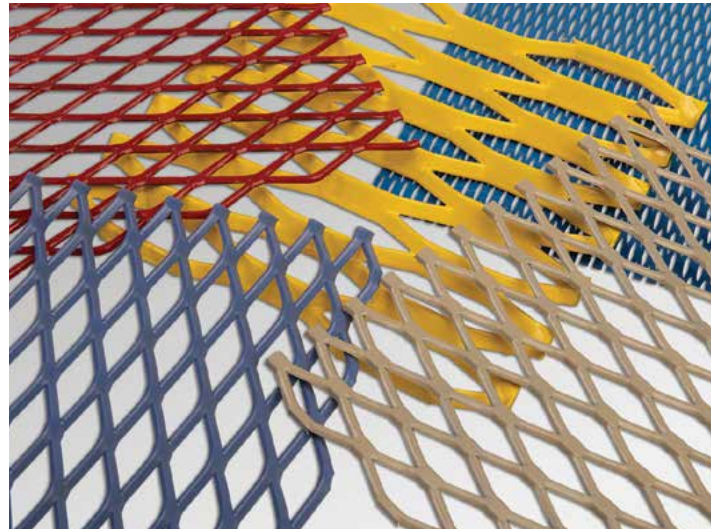
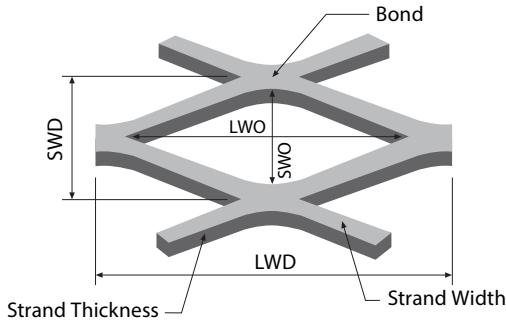

## Expanded Metal Products



Standard (Raised)

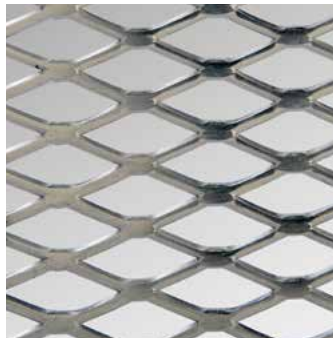

Flattened

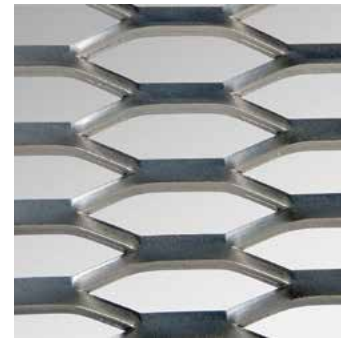

Expanded Metal Grating

## Expanded Metal Terminology

**DIAMOND:** The open area formed by strands and bonds.

**STRAND:** The single metal strip that forms the perimeter of the diamond.

**BOND:** The point where adjacent strands meet.

**LWD:** Long way of the diamond, the distance from the center of one bond to the center of the next bond across the longer opening of the diamond.

**SWD:** Short way of the diamond, the center-to-center distance between bonds across the narrow opening of the diamond.

**LWO:** Long way of the opening, the clear opening of the diamond in the long direction of the diamond.

**SWO:** Short way of the opening, the clear opening of the diamond across the short direction of the diamond.

## Regular vs. Flattened Expanded Metal

Standard expanded metal, also known as “raised” or “regular” expanded metal is raised at the bonds of the diamond. The resulting sheet has a surface that is rough to the touch and is also more rigid. Ideal for industrial applications where public contact is limited.

Flattened expanded metal has been passed through rollers and is smooth across each bond. Ideal for screening applications.

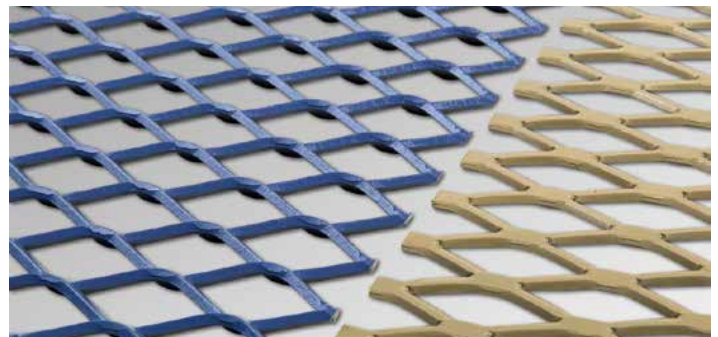

## Pattern Orientation

**STANDARD FLOW:** Pattern runs with the LWD running the length of the sheet and the SWD running across the width of the sheet.

**REVERSE FLOW:** Pattern runs with the LWD running across the width of the sheet and the SWD running the length of the sheet.

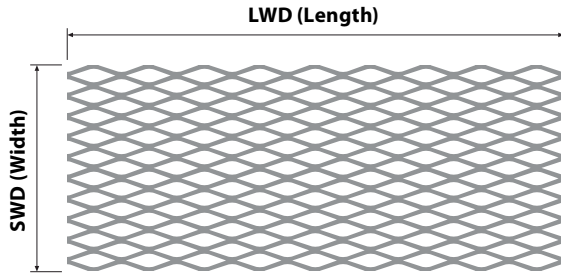

## Shearing

**BOND SHEAR:** The expanded metal sheet is cut through the center of the bonds resulting in closed diamond at the edge of the sheet.

**RANDOM SHEAR:** The expanded metal sheet is cut through diamonds resulting in partial diamonds at the sheet's edge. The partial diamonds result in exposed strands that are very sharp and should be protected with U-Edging or framing.

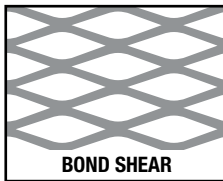

## How to Specify / Order Expanded Metal

### MATERIAL

Indicate type of material desired (carbon steel, stainless steel, or aluminum).

### STYLE NUMBER

Indicate style number (such as 3/4-#9R) which will indicate the desired diamond size and sheet thickness.

### SURFACE

Confirm desired surface, regular or flattened sheet.

### QUANTITY & SIZE

Indicate quantity desired and piece sizes including SWD and LWD. Provide material list for cut-to-size pieces and sketches for irregular shapes. For sheared to size orders, review shearing options previously illustrated.

### FABRICATION REQUIREMENTS

Indicate U-edging or other fabrication requirements.

### FINISHING

Specify any special finish requirements (galvanizing, paint, or anodizing).

## FABRICATION & FINISHES

### Fabrication

Our fabrication teams are highly trained and ready to shear, form, roll, frame, or otherwise customize any expanded metal order as specified by the customer. These services can be provided to a single sheet or turnkey projects depending on customer requirements. Engineering and layout services are also available.



### Shearing

We can shear any sheet to meet your project requirement. Please clearly specify your preference for bond shear or random shear at the time of ordering.



### U-Edging

U-Edging is available from stock in 10' or 12' lengths of carbon steel, aluminum, or stainless steel. Alloy dependent, openings range from 1/16" to 1/2" with 1" overall width. Custom sizes are available on special order.

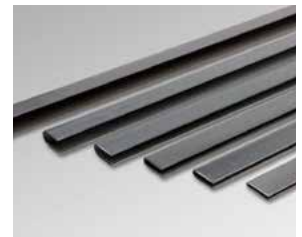

### Angle & Custom Framing

Angle framing adds rigidity and a uniform, geometric look to the panel. Popular for infill panels, partitions, or equipment guards, perimeter angles are available in a wide range of sizes.

Our fabrication specialists have experience with a wide range of custom designed framing options. Nested flat bars, tube framing, and channel framing can be designed and fabricated to complement adjacent architecture.

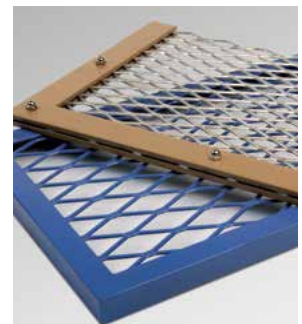



## STANDARD (RAISED) EXPANDED METAL

Also known as “regular” expanded metal as it is raised at the bonds of the diamond. Ideal for industrial applications where public access is limited.

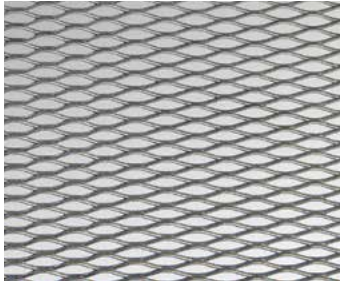
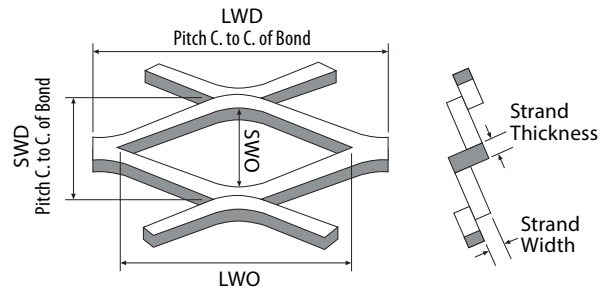

1/4" Diamond (SWD) Opening

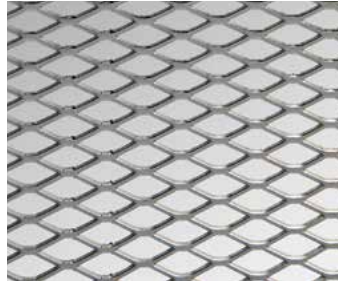

1/2" Diamond (SWD) Opening



3/4" Diamond (SWD) Opening



1-1/2" Diamond (SWD) Opening

### STANDARD EXPANDED METAL NOMINAL WEIGHTS & DIMENSIONS

Style	Minimum Thickness (inches)	Nominal Weight in lbs./100 Sq. Ft.	Design Size (inches)		Opening Size (inches)		Strand Size (inches)		Overall Thickness (inches)	Open Area
			SWD	LWD	SWO	LWO	WIDTH	THICKNESS		
<b>Standard-Carbon Steel</b>										
1/4-#20	0.032	85	0.250	1.000	0.157	0.718	0.072	0.036	0.146	42%
1/4-#18	0.042	113	0.250	1.000	0.146	0.718	0.072	0.048	0.151	42%
1/2-#20	0.032	42	0.500	1.200	0.407	0.938	0.072	0.036	0.146	71%
1/2-#18	0.042	69	0.500	1.200	0.382	0.938	0.088	0.048	0.180	65%
1/2-#16	0.053	85	0.500	1.200	0.372	0.938	0.087	0.060	0.183	65%
1/2-#13	0.083	141	0.500	1.200	0.337	0.938	0.096	0.090	0.212	62%
3/4-#16	0.053	54	0.923	2.000	0.783	1.750	0.101	0.060	0.208	78%
3/4-#13	0.083	77	0.923	2.000	0.760	1.688	0.096	0.090	0.212	79%
3/4-#10	0.083	117	0.923	2.000	0.718	1.625	0.144	0.092	0.300	69%
3/4-#9	0.127	178	0.923	2.000	0.675	1.562	0.150	0.134	0.329	67%
1-1/2-#18	0.042	20	1.330	3.000	1.229	2.625	0.068	0.048	0.144	90%
1-1/2-#16	0.053	40	1.330	3.000	1.184	2.625	0.108	0.060	0.221	84%
1-1/2-#13	0.083	58	1.330	3.000	1.160	2.500	0.105	0.090	0.228	84%
1-1/2-#10	0.083	76	1.330	3.000	1.132	2.500	0.138	0.090	0.288	79%
1-1/2-#9	0.127	119	1.330	3.000	1.087	2.375	0.144	0.134	0.318	78%
1-1/2-#6	0.184	247	1.330	3.000	0.979	2.313	0.203	0.198	0.452	69%
2-#10	0.083	65	1.850	4.000	1.630	3.438	0.164	0.090	0.335	82%
2-#9	0.127	88	1.850	4.000	1.603	3.375	0.149	0.134	0.327	84%
<b>Standard-Stainless Steel</b>										
1/2-#18	0.044	69	0.500	1.200	0.383	0.937	0.087	0.048	0.178	65%
1/2-#16	0.055	87	0.500	1.200	0.372	0.937	0.087	0.060	0.183	65%
1/2-#13	0.085	143	0.500	1.200	0.337	0.876	0.096	0.090	0.212	62%
3/4-#18	0.044	46	0.923	2.000	0.790	1.750	0.106	0.048	0.212	77%
3/4-#16	0.055	57	0.923	2.000	0.779	1.760	0.106	0.060	0.217	77%
3/4-#13	0.085	87	0.923	2.000	0.751	1.687	0.107	0.090	0.232	77%
3/4-#9	0.128	194	0.923	2.000	0.666	1.562	0.160	0.135	0.347	65%
1-1/2-#16	0.055	43	1.330	3.000	1.179	2.750	0.115	0.060	0.234	83%
1-1/2-#13	0.085	65	1.330	3.000	1.152	2.625	0.115	0.090	0.246	83%
1-1/2-#9	0.128	130	1.330	3.000	1.077	2.500	0.155	0.135	0.338	77%
<b>Standard-Aluminum</b>										
1/2-.050	0.045	26	0.500	1.200	0.376	0.937	0.093	0.050	0.190	63%
1/2-.080	0.074	43	0.500	1.200	0.346	0.937	0.096	0.080	0.208	62%
3/4-.050	0.045	17	0.923	2.000	0.786	1.750	0.109	0.050	0.219	76%
3/4-.080 (Lght)	0.074	31	0.923	2.000	0.741	1.680	0.129	0.080	0.268	72%
3/4-.080 (Hvy)	0.074	40	0.923	2.000	0.711	1.680	0.165	0.080	0.333	64%
3/4-.125	0.118	64	0.923	2.000	0.667	1.680	0.169	0.125	0.359	63%
1-1/2-.080	0.074	22	1.330	3.000	1.149	2.500	0.128	0.080	0.266	81%
1-1/2-.125	0.118	43	1.330	3.000	1.080	2.500	0.162	0.125	0.346	76%

A tolerance of ± 10% is permitted in all weights and dimensions except for minimum strand thickness.

For additional information click link:  
[Standard Expanded Metal Products](#)

## FLATTENED EXPANDED METAL

Having a smooth, flat surface, this product is lightweight and ideal for use in a wide variety of industrial and architectural applications that are accessible to the public.

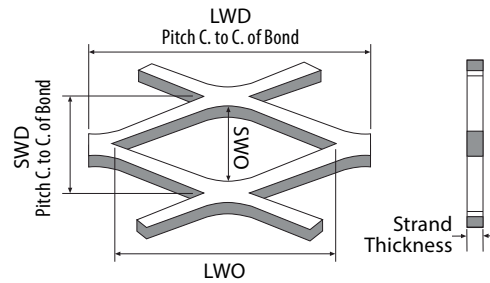

1/4" Diamond (SWD) Opening

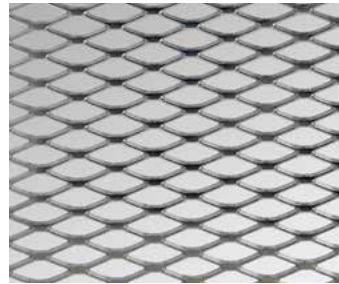

1/2" Diamond (SWD) Opening



3/4" Diamond (SWD) Opening



1-1/2" Diamond (SWD) Opening

### FLATTENED EXPANDED METAL WEIGHTS & DIMENSIONS

Style	Minimum Thickness (inches)	Nominal Weight in lbs./100 Sq. Ft.	Design Size (inches)		Opening Size (inches)		Strand Size (inches)		Overall Thickness (inches)	(% Open Area)
			SWD	LWD	SWO	LWO	WIDTH	THICKNESS		
<b>Flattened-Carbon Steel</b>										
1/4-#20	0.026	74	0.250	1.050	0.092	0.715	0.079	0.029	0.029	37%
1/4-#18	0.034	100	0.250	1.050	0.090	0.715	0.080	0.038	0.038	36%
1/2-#20	0.026	37	0.500	1.260	0.342	1.000	0.079	0.029	0.029	68%
1/2-#18	0.034	61	0.500	1.260	0.306	1.000	0.097	0.038	0.038	61%
1/2-#16	0.043	77	0.500	1.260	0.304	1.000	0.098	0.048	0.048	61%
1/2-#13	0.066	126	0.500	1.260	0.286	1.000	0.107	0.072	0.072	57%
3/4-#16	0.043	47	0.923	2.100	0.701	1.750	0.111	0.048	0.048	76%
3/4-#14	0.054	56	0.923	2.100	0.713	1.760	0.105	0.060	0.060	77%
3/4-#13	0.066	67	0.923	2.100	0.711	1.781	0.106	0.072	0.072	77%
3/4-#10	0.066	102	0.923	2.100	0.603	1.755	0.160	0.072	0.072	65%
3/4-#9	0.101	157	0.923	2.100	0.593	1.168	0.165	0.108	0.108	64%
1-1/2-#16	0.043	35	1.330	3.150	1.092	2.750	0.119	0.048	0.048	82%
1-1/2-#14	0.054	43	1.330	3.150	1.098	2.750	0.116	0.060	0.060	83%
1-1/2-#13	0.066	51	1.330	3.150	1.098	2.750	0.116	0.072	0.072	83%
1-1/2-#9	0.101	105	1.330	3.150	1.014	2.563	0.158	0.108	0.108	76%
<b>Flattened-Stainless Steel</b>										
1/2-#18	0.037	66	0.500	1.260	0.304	1.000	0.098	0.041	0.041	61%
1/2-#16	0.047	84	0.500	1.260	0.302	1.000	0.099	0.051	0.051	60%
1/2-#13	0.072	136	0.500	1.260	0.286	0.915	0.107	0.076	0.076	57.00%
3/4-#18	0.037	43	0.923	2.100	0.687	1.812	0.118	0.041	0.041	74%
3/4-#16	0.047	54	0.923	2.100	0.687	1.812	0.118	0.051	0.051	74%
3/4-#13	0.072	83	0.923	2.100	0.683	1.750	0.120	0.076	0.076	74%
3/4-#9	0.108	185	0.923	2.100	0.593	1.687	0.179	0.114	0.114	61%
1-1/2-#16	0.047	41	1.330	3.150	1.074	2.750	0.128	0.051	0.051	81%
1-1/2-#13	0.072	62	1.330	3.150	1.070	2.625	0.130	0.076	0.076	80%
1-1/2-#9	0.108	124	1.330	3.150	0.960	2.625	0.174	0.114	0.114	74%
<b>Flattened-Aluminum</b>										
1/2-.050	0.034	22	0.500	1.260	0.292	1.000	0.104	0.038	0.038	58%
1/2-.080	0.056	35	0.500	1.260	0.290	1.000	0.105	0.060	0.060	58%
3/4-.050	0.034	14	0.923	2.100	0.679	1.812	0.122	0.038	0.038	74%
3/4-.080 (Light)	0.056	26	0.923	2.100	0.637	1.750	0.143	0.060	0.060	69%
3/4-.080 (Heavy)	0.056	33	0.923	2.100	0.561	1.750	0.181	0.060	0.060	61%
3/4-.125	0.089	53	0.923	2.100	0.549	1.750	0.187	0.094	0.094	59%
1-1/2-.080	0.056	18	1.330	3.150	1.044	2.750	0.143	0.060	0.060	78%
1-1/2-.125	0.089	36	1.330	3.150	0.968	2.750	0.181	0.094	0.094	73%

A tolerance of ± 10% is permitted in all weights and dimensions except for minimum strand thickness.

For additional information click link:  
[Flattened Expanded Metal Products](#)



## EXPANDED METAL GRATING

Expanded Metal Grating is a lightweight, economical alternative for short span catwalks and maintenance platforms. Available in distinct hexagonal or diamond patterns, standard products are produced with the long way of the opening “spanning” the length (long direction) of the sheet. Reverse flow Expanded Metal Catwalk Grating is an excellent option for walkways. It is produced with the long way of the diamond “spanning” the width or short direction of the sheet, providing increased load bearing capacity.



**Hexagonal Surface**

Available in 2#, 3#, 4#, 5#, 6.25#, and 7#

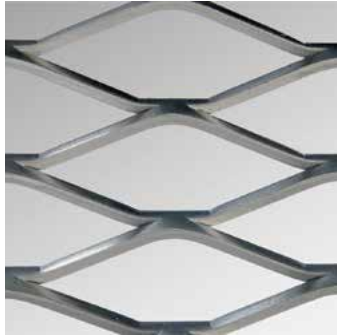

**3.14# Diamond Opening**

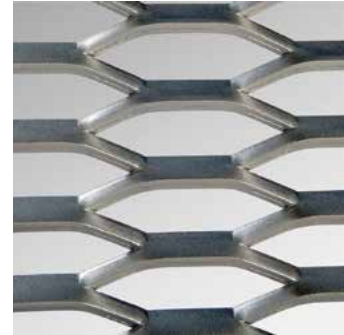

**4.27# Diamond Opening**

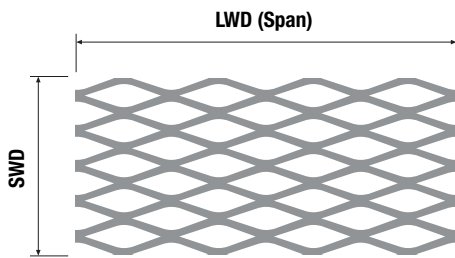

**STANDARD FLOW EXPANDED METAL GRATING**

The long way of the diamond (LWD) or hexagon runs the length (long dimension) of the sheet

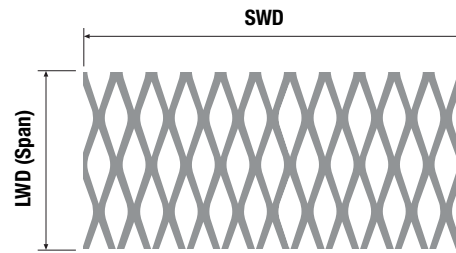

**REVERSE FLOW EXPANDED METAL CATWALK GRATING**

The long way of the diamond (LWD) or hexagon runs the width (short dimension) of the sheet

### EXPANDED METAL GRATING WEIGHTS & DIMENSIONS

Style	Lbs. per Sq. Ft.	Standard Sheet Size (feet)		Design Size (inches)		Opening Size (inches)		Strand Size (inches)		Overall Thickness (inches)	(% Open Area)
		SWD	LWD	SWD	LWD	SWO	LWO	WIDTH	THICKNESS		
<b>Carbon Steel (ASTM A 1008/A 1008M)</b>											
3.0 lb.	3.00	4, 5 & 6	8, 10 & 12	1.33	5.33	0.940	3.44	0.264	0.183	0.540	60%
3.14 lb.	3.14	4, 5 & 6	8 & 10	2.00	6.00	1.625	4.88	0.312	0.250	0.656	69%
4.0 lb.	4.00	4, 5 & 6	8 & 10	1.33	5.33	0.940	3.44	0.300	0.215	0.618	55%
4.27 lb.	4.27	4 & 6	8 & 10	1.41	4.00	1.00	2.88	0.300	0.250	0.625	58%
5.0 lb.	5.00	4, 5 & 6	8 & 10	1.33	5.33	0.813	3.38	0.331	0.250	0.655	50%
6.25 lb.	6.25	4, 5 & 6	8 & 10	1.41	5.33	0.813	3.38	0.350	0.312	0.715	50%
7.0 lb.	7.00	4, 5 & 6	8 & 10	1.41	5.33	0.813	3.38	0.391	0.318	0.740	45%
<b>Stainless Steel - Types 304 or 316 (including extra low carbon grades) (ASTM A-666)</b>											
3.3 lb.	3.32	4	8	2.00	6.00	1.625	4.88	0.312	0.250	0.665	69%
4.5 lb.	4.25	4	8	1.41	4.00	1.000	2.88	0.300	0.250	0.625	58%
<b>Aluminum Type 5052-H-32 (ASTM B 209)</b>											
2.0 lb.	2.00	4	8	1.33	5.33	0.940	3.44	0.387	0.250	0.730	48%

A tolerance of ± 10% is permitted in all weights and dimensions except for minimum strand thickness.

For additional load table information click link:

[Expanded Metal Grating](#)

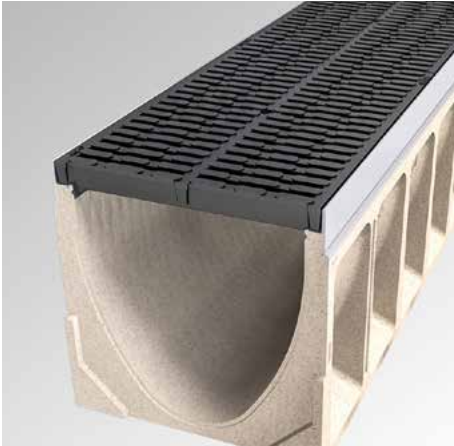
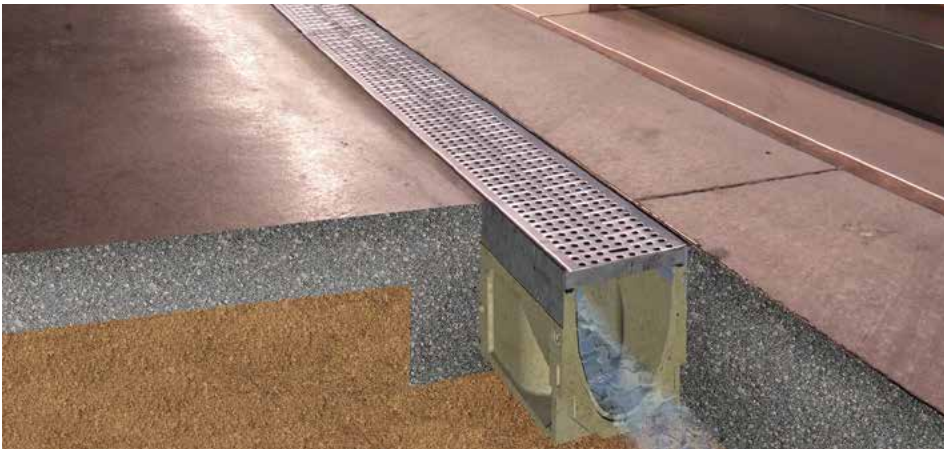

# ACO TRENCH DRAIN SYSTEMS





## ACO TRENCH DRAIN SYSTEMS

ACO Trench Drain Systems consist of corrosion-resistant polymer concrete or fiberglass channels paired with protective edge frames and grate covers. Available in 2", 4", 8", and 12" internal widths, most systems include a built-in slope and grates capable of supporting loads from pedestrian to aircraft traffic.

- Modular system for efficient installation
- Smooth internal channel walls for effective drainage
- Wide range of load applications
- Diverse grate options
- Full and half meter channels provide up to 130' of continuous slope



### ACO Trench Drain System Products

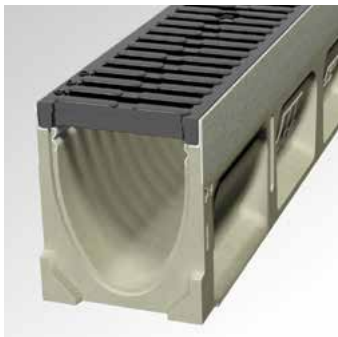

**KlassikDrain**

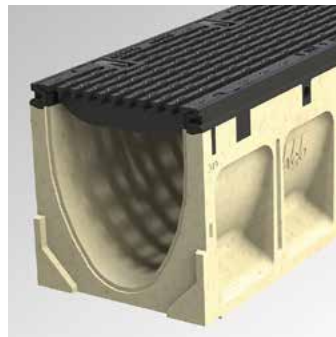

**PowerDrain**

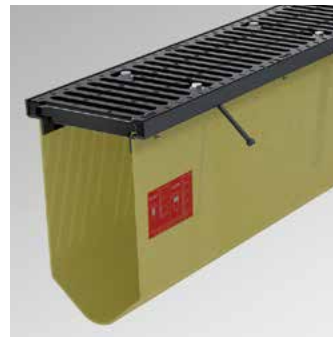

**FlowDrain**

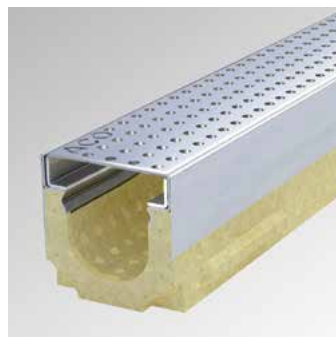

**MiniKlassik**

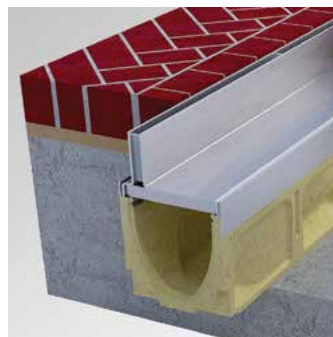

**BrickSlot**

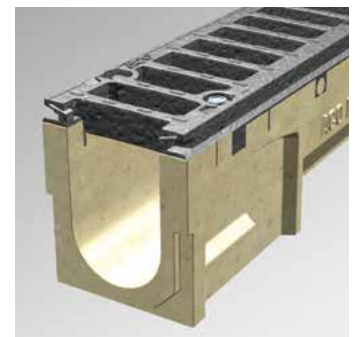

**HighwayDrain  
& TrafficDrain**

## KLASSIKDRAIN

Our most popular ACO Drain product line, KlassikDrain is a general-purpose polymer concrete trench drain system with channels available in 4" (K100), 8" (K200) or 12" (K300) internal widths.

- Channels are manufactured with 0.5% standard slope
- 40 continuous one-meter sections
- Protective edge rails in galvanized steel (K series) or 304 stainless steel (KS series)
- Wide range of grates from ADA-compliant to heavy vehicular and airport rated

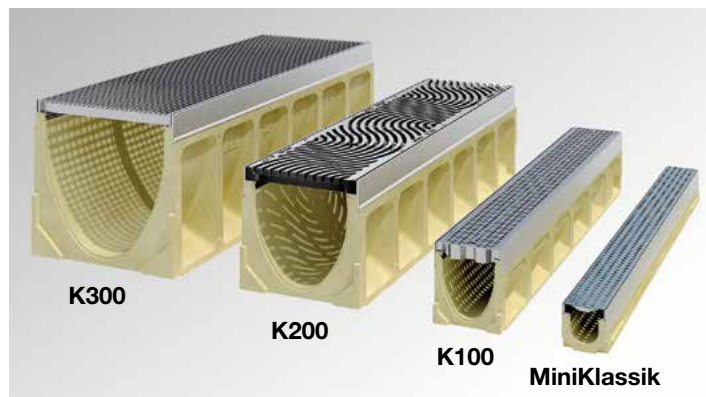

## Installation is Easy

- Interconnected channels allow for quick installation
- QuikLok or Drainlok boltless locking system allows for rapid installation and easy removal of grates
- Directional arrows indicate drainage flow to aid in proper installation
- Knock outs at every 5th channel allow for vertical evacuation of system
- In-line catch basins available and easy to install
- Optional channel seats assist installation

## KlassikDrain System Layout

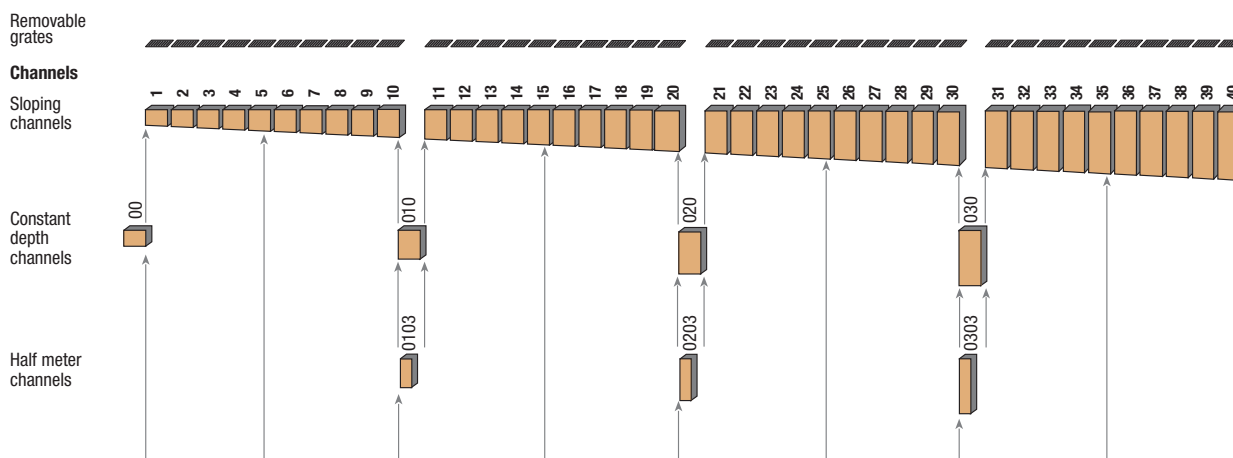

## MiniKlassik K50/KS50

K50 is a 2" internal width system with galvanized steel edge rails for aesthetic applications where a barrier is required to separate wet and dry areas. KS50 is the same system, but the edge rails are grade 304 stainless steel. KS50 should be used where appearance is paramount or where increased corrosion resistance is required.

Product Features:

- One-meter constant depth, non-sloping polymer concrete channels
- Interconnecting end profiles allow for easy assembly
- Aesthetic ADA conforming grate options
- Ideal for pedestrian plazas and sidewalks



## MiniKlassik System Layout

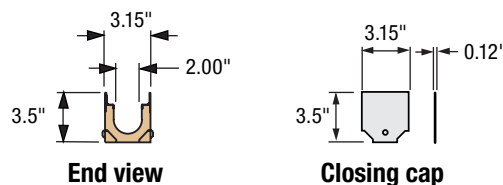
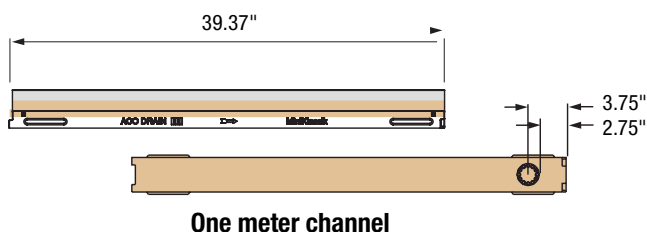

For additional information on MiniKlassik and KS50 click link: [MiniKlassik Products](#)



# ACO TRENCH DRAIN SYSTEMS

## POWERDRAIN

Heavy Duty PowerDrain is a stout polymer concrete trench drain system with cast iron edges designed for heavy vehicular and aircraft loads. Available in 4" (S100K), 8" (S200K), or 12" (S300K) internal widths.

- Channels are manufactured with 0.5% standard slope
- 40 continuous one-meter sections
- Protective edge rails are heavy duty ductile cast iron
- Robust ductile iron grates support heavy vehicular and airport rated traffic



### PowerDrain Ease of Installation

- Interconnected channels allow for quick installation
- Bolted locking system
- Directional arrows indicate drainage flow
- Knock outs allow for vertical evacuation of system
- In-line catch basins available and easy to install

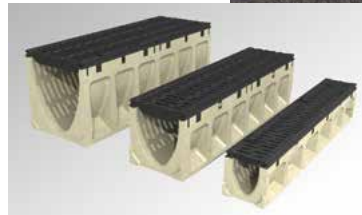

## FLOWDRAIN FG200

FG200 is an 8" (200 mm) internal width fiberglass system with a surface mounted steel frame. Grate options are Class C slotted steel or Class E ductile cast iron. Grates are bolted into the steel frame with 2 bolts per 18" grate.

The FG200 system is available in twelve, interconnecting, 9-foot long channels with a built in 1.0% slope.

Typical installations include:

- Parking lots & garages
- Commercial and industrial areas
- Airports
- Interior applications



## BRICKSLOT

A discreet drainage solution for use with brick or stone pavers. The 7/16" slot blends in with the paving joints giving an aesthetic appearance. BrickSlot 100 overlays KlassikDrain K100 4" (100 mm) channels. BrickSlot 200 overlays KlassikDrain K200 8" (200mm) channels.



### BrickSlot System Layout

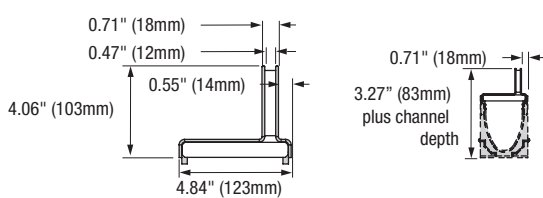

**BrickSlot 100**

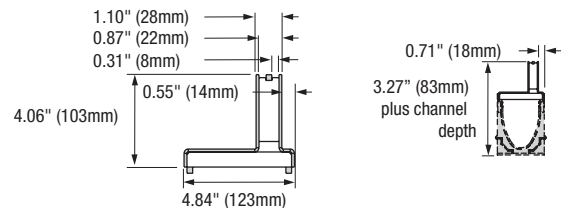

**Heel Resistant BrickSlot 100**

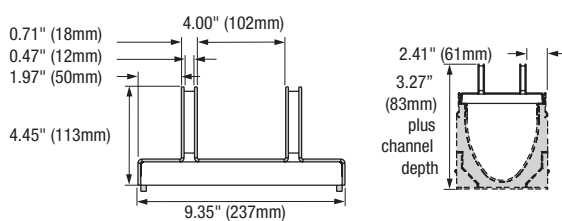

**TwinSlot 200**

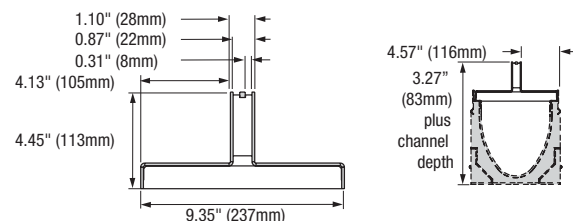

**Heel Resistant BrickSlot 200**

## ACO SYSTEMS

### Grates



All ACO Trench Drain systems come with numerous grate options rated for a variety of loads from pedestrian to vehicular traffic. Designer grates are available for applications where architectural appeal is important.

### Catch Basins



Each ACO system has optional catch basins that can be used as a stand-alone area drain, or more commonly as the outlet to a trench run. Catch basins provide high hydraulic output and allow easy access to the pipe system for maintenance.

### Accessories



End Cap/Closing Inlet/Outlet Cap

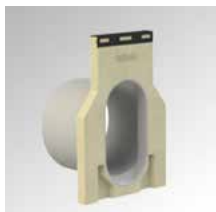

Schedule 40 6" Inlet/Outlet Caps



Oval to Schedule 40 6" Pipe



Foul Air Trap (FAT)



Installation Device



Vertical Outlet Strainer

For additional information on all ACO Drain products click link: [ACO Trench Drain Systems](#)

## HighwayDrain and TraffikDrain

ACO Drain offers a complete line of drainage solutions for road and highway conditions. Two popular systems are HighwayDrain and TraffikDrain.

HighwayDrain is a monolithic, single-piece, polymer concrete grate and channel with a pre-sloping 8" internal width. Modules are constructed with male-female connecting ends for efficient and permanent installation. With 30% open area, HighwayDrain allows for rapid drainage of roadways.

TraffikDrain consists of a durable polymer concrete channel with ductile iron edge rails and grates. Built with a 4" internal width, TraffikDrain is available in 60 one-meter modules with a built in 0.6% slope. Bolted grates ensure safety.



### HighwayDrain

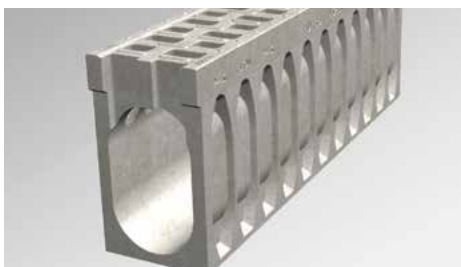

### TraffikDrain

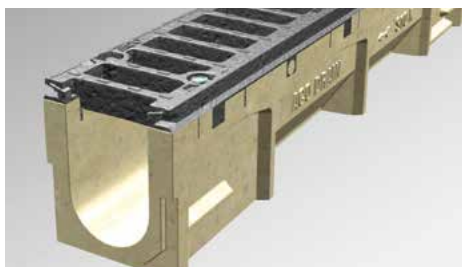

For additional information on all ACO Drain products click link: [ACO Trench Drain Systems](#)



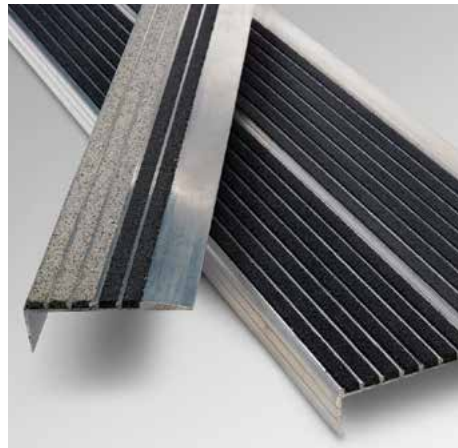

# STAIR NOSINGS & COVERS





## STAIR NOSINGS & COVERS

Safety, durability, and impact resistance are just some of the features that make Grating Pacific SuperTread Nosings and Tread Covers preferred components for stairs and landings. SuperTread products are available in extruded aluminum carriers with a solid abrasive fill; cast iron, cast aluminum, or cast bronze abrasive.

Maximum pedestrian safety is provided by the anti-slip walking surface and OSHA conforming, barrier-free installation. SuperTread Nosings form a highly visible, defined, leading edge at the primary point of contact on stairs and landings. Impact-resistant nosings protect concrete edges that are prone to chipping and cracking.



### Types of SuperTread Stair Nosings & Covers

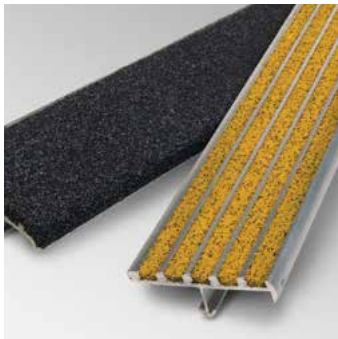

**Extruded Aluminum Stair Nosings**



**Cast Abrasive Stair Nosings**

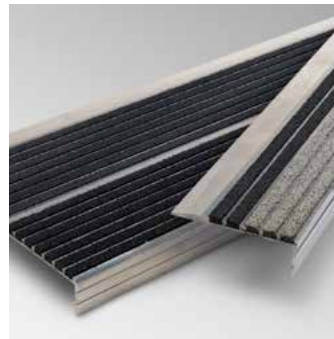

**Extruded Aluminum Stair Covers**

## SUPERTREAD ALUMINUM STAIR NOSINGS

SuperTread Extruded Aluminum Nosings are manufactured with a base container of 6061-T5 extruded aluminum filled with an abrasive mixture of aluminum oxide and silicon blend, compacted and bonded by 100% solid epoxy. Extruded nosings are designed for installation during a new concrete pour and are available in lengths up to 24'. Stock colors are black or yellow, with a wide range of optional colors available on special order. Two inch wide safety strips are available for California Title 24 code compliance.

**For additional information click link:**  
[\*\*SuperTread Stair Nosings & Covers\*\*](#)





# STAIR NOSINGS & COVERS

## Extruded Aluminum Stair Nosing Details

### RIBBED ABRASIVE STAIR NOSINGS

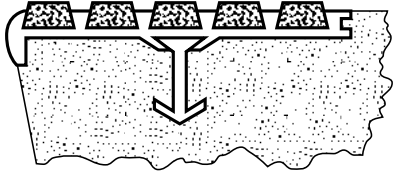

#### Type XRS

Widths: 2", 3", 4"  
Depth: 1/4"

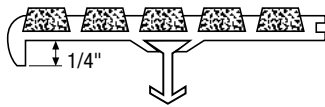

#### Type XTS

Widths: 2", 3", 4"  
Depth: 1/4"

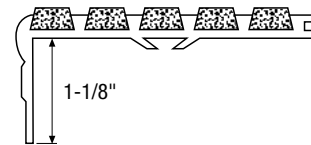

#### Type XRF

Widths: 1-3/8", 3"  
Depth: 1/4"



#### Type XTL

Widths: 2", 3", 4"  
Depth: 1/4"

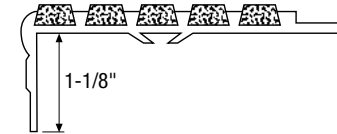

#### Type XRL

Widths: 2", 3", 4"  
Depth: 1/4"

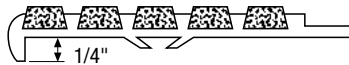

### SOLID ABRASIVE STAIR NOSINGS

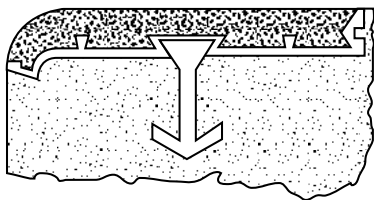

#### Type XSS

Widths: 2", 3", 4"  
Depth: 3/8"

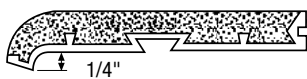

#### Type XSR

Widths: 2", 3", 4"  
Depth: 3/8"

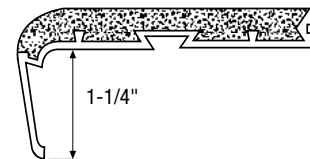

For additional information click link:  
[SuperTread Stair Nosings & Covers](#)

# STAIR NOSINGS & COVERS

## STEEL PAN TREAD NOSINGS

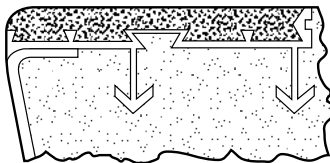

### Type XSB

Widths: 2", 3", 4"  
Depth: 3/8"



### Type XSS

(Barrier Free Design)  
Widths: 2", 3", 4"  
Depth: 3/8"

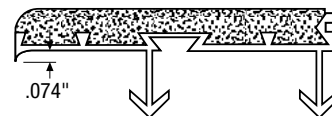

### Type XRS

(Barrier Free Design)  
Widths: 2", 3", 4"  
Depth: 1/4"

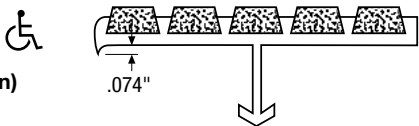

### Type XRR

Widths: 3"  
Depth: 1/4"

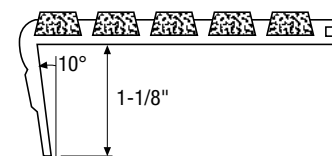

## CALIFORNIA TITLE 24 SAFETY STRIPS

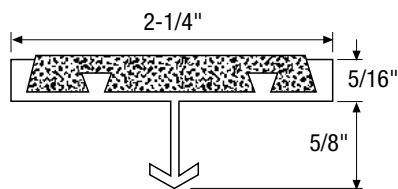

With extruded anchor for poured stairs.

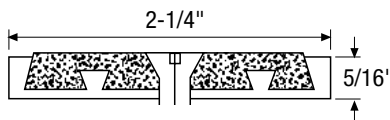

With holes for screws and fasteners.

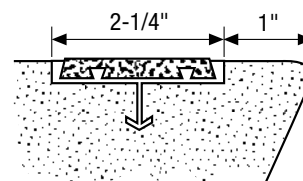

Meets all requirements of California Title 24 safety strip for the visually impaired.

## CAST ABRASIVE STAIR NOSINGS

SuperTread Cast Abrasive Stair Nosings are castings with abrasive grit embedded to a minimum depth of 1/16 inch in the wear surface. Cross hatching or fluted top surface is clean and well defined to a minimum depth of 1/16 inch. Produced in lengths up to 8'-0", materials available include cast aluminum, cast iron, and bronzacast.

### Sizes & Options Include:

- Type C-01
- Type C-01-SP
- Type C-02
- Type C-03
- Type C-04
- Type C-16
- Type C-20



## TYPE C-01 CAST NOSINGS

### Type C-01 Cast Nosings

Our most popular cast nosing, type C-01 is designed for use on concrete stairs, installed during construction. Stock materials are cast aluminum and cast iron, in 3" and 4" widths, in lengths up to 8'-0". Also available in Bronzecast.

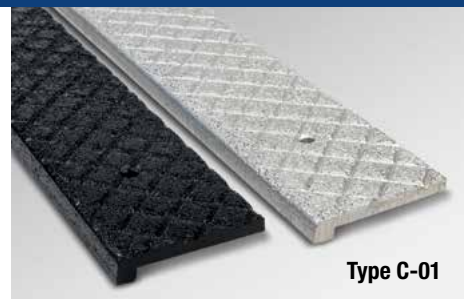
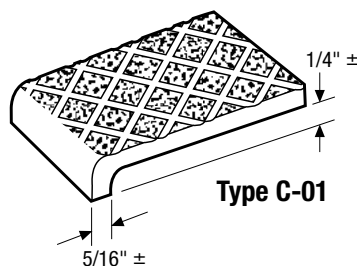

Type C-01





# ONGRIP & ALGRIP SLIP-RESISTANT FLOORING





## ONGRIP® SLIP-RESISTANT FLOORING

Slip-resistant floor plates and grating are created by applying OnGrip spray traction surface to stainless steel, carbon steel, and aluminum plate or grating. OnGrip flooring is commonly used in both commercial and industrial applications where surfaces are routinely exposed to fluids and lubricants. OnGrip slip-resistant flooring provides enhanced safety and traction in areas that frequently experience high levels of pedestrian traffic.



## ALGRIP SLIP-RESISTANT FLOORING

Algrip traction surfaces are available on both grating and floor plate options. This versatility allows for a variety of applications in commercial settings and pedestrian areas. A patented process welds metal deposits to stainless steel, carbon steel, and aluminum floor plates and grating, creating increased traction in all directions. Algrip grating and floor plate products are ADA compliant and are commonly used in applications that are subject to the accumulation of moisture.

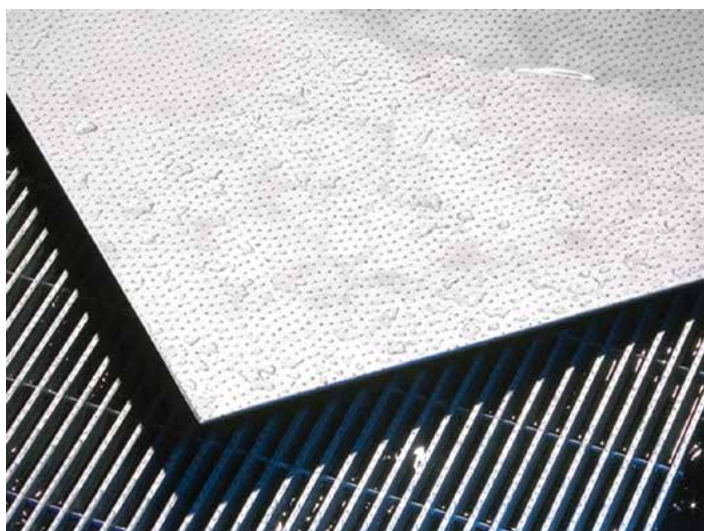

### Fabrication

OnGrip and Algrip are easily fabricated by:

- Punching & Drilling
- Welding
- Forming
- Countersink
- Shearing
- Flame Cutting

## ALGRIP SLIP-RESISTANT LADDER RUNGS

Algrip Slip Resistant Ladder rungs provide an extremely durable surface designed to provide safer ascent and descent for workers. Algrip Ladder Rungs meet OSHA requirements for fixed metal ladders of all types.

- Available in 3/4" or 1" diameter
- Materials: Carbon Steel, Stainless Steel, Aluminum

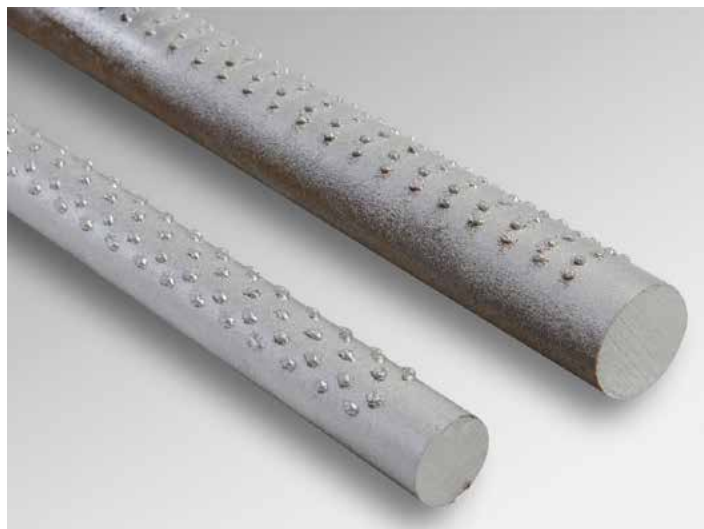

**For additional information click link:**  
[Algrip Slip-Resistant Flooring](#)





# DOCK & DECK SOLUTIONS



## THRU-FLOW™

ThruFlow™ is an interlocking molded polypropylene grate manufactured in stock sizes. Ideal for boat docks and ramps. The grates are light-weight, long-lasting, maintenance free, and simple to install. The walking surface is ADA compliant, slip-resistant, and cool under bare feet. Legacy XP and Legacy products in stock, other ThruFlow products available upon special order.

Features:

- LegacyXP available in 1'x3', 1'x4', and 1'x5'
- Legacy panels available in 1'x3', 1'x4', 1'x5', and 4'x4'
- 43% open area
- Color options include light grey, and maple



## SUNWALK™

Sunwalk Decking and Dock solutions feature the Sunwalk 90 Series and Sunwalk 45 Series interlocking, polypropylene grates. With clean lines, and uniform design, Sunwalk products are easy to install, durable, and storm resistant. All products feature an ADA compliant, slip-resistant walking surface that stays cool to the touch as the weather warms up. Sunwalk 90 Series features a slotted, linear pattern, Sunwalk 45 Series features a diagonal slotted pattern.

Features:

- Sunwalk 90 Series available in 1'x3', 1'x4', 2'x4', and 1'x5'
- Sunwalk 45 Series available in 3'x4', 4'x4', and 4'x5'
- 45% open area
- Color options include oak and stone



## ECOGRATE® 62

ADA compliant Ecograte 62 is designed to meet requirements of the National Marine Fisheries Service and U.S. Army Corps of Engineers for marine decking and docks. Ecograte has a 62% open area and is available with coarse or fine grit surface options. See Page 45 for more details.



For additional information click link:

[Dock & Deck Products](#)





3651 Sausalito Street  
Los Alamitos, CA 90720

## CHANGE SERVICE REQUESTED



**Southern California**  
3651 Sausalito Street  
Los Alamitos, CA 90720  
(800) 321-4314  
(562) 598-4314

**Northern California**  
1398 Mariani Court, # 120  
Tracy, CA 95376  
(800) 491-7999  
(209) 832-6363

**Oregon**  
2775 N. Front Street  
Woodburn, OR 97071  
(800) 942-4041  
(503) 980-2060

**Washington**  
19411 66th Avenue South  
Kent, WA 98032  
(800) 243-3939  
(253) 872-7733

**Arizona**  
8401 W. Sherman Street  
Tolleson, AZ 85353  
(888) 936-9201  
(623) 936-9200

For more information, visit our website: [www.gratingpacific.com](http://www.gratingpacific.com) / Email: [sales@gratingpacific.com](mailto:sales@gratingpacific.com)